

Needs and Solutions for Documenting Commissioning

Michael J. King, FCSI, CCS, MAI

Vice President of Engineering Specifications

ARCOM – Publishers of MASTERSPEC

Commissioning Process Guidelines

Commissioning Guidelines

- Outline objectives and tasks for each project delivery phase
 - Follow traditional project delivery phases:
 - Pre-design
 - Design
 - Construction
 - Owner occupancy and operation
-

GUIDELINES RELATIONSHIP

Guideline 0 – The Commissioning Process

Guideline
1 – The
HVAC
Cx
Process

Guideline

Guideline
3 – The
Exterior
Envelope
Cx
Process

Guideline

GUIDELINES RELATIONSHIP

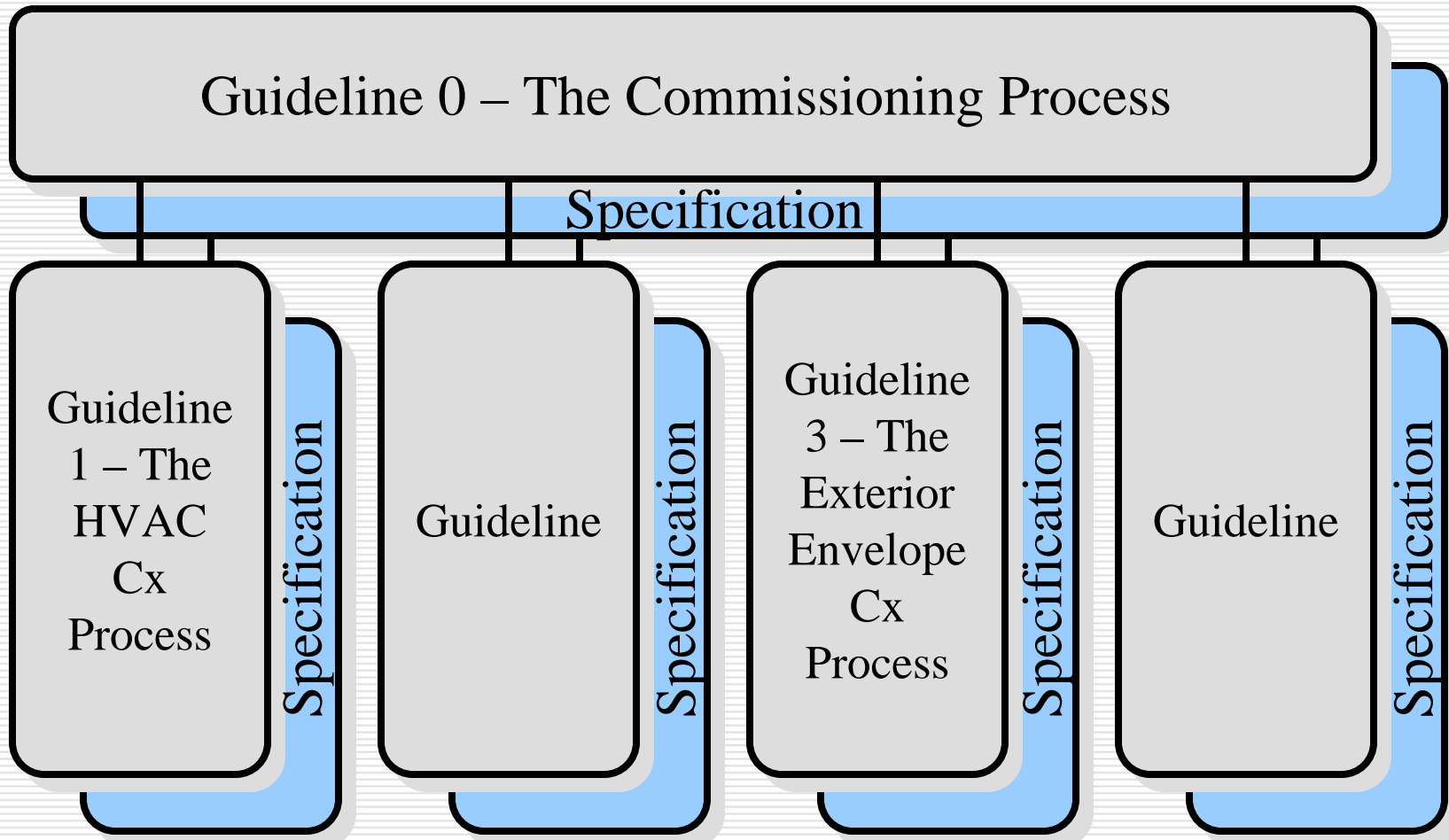

GUIDELINES RELATIONSHIP

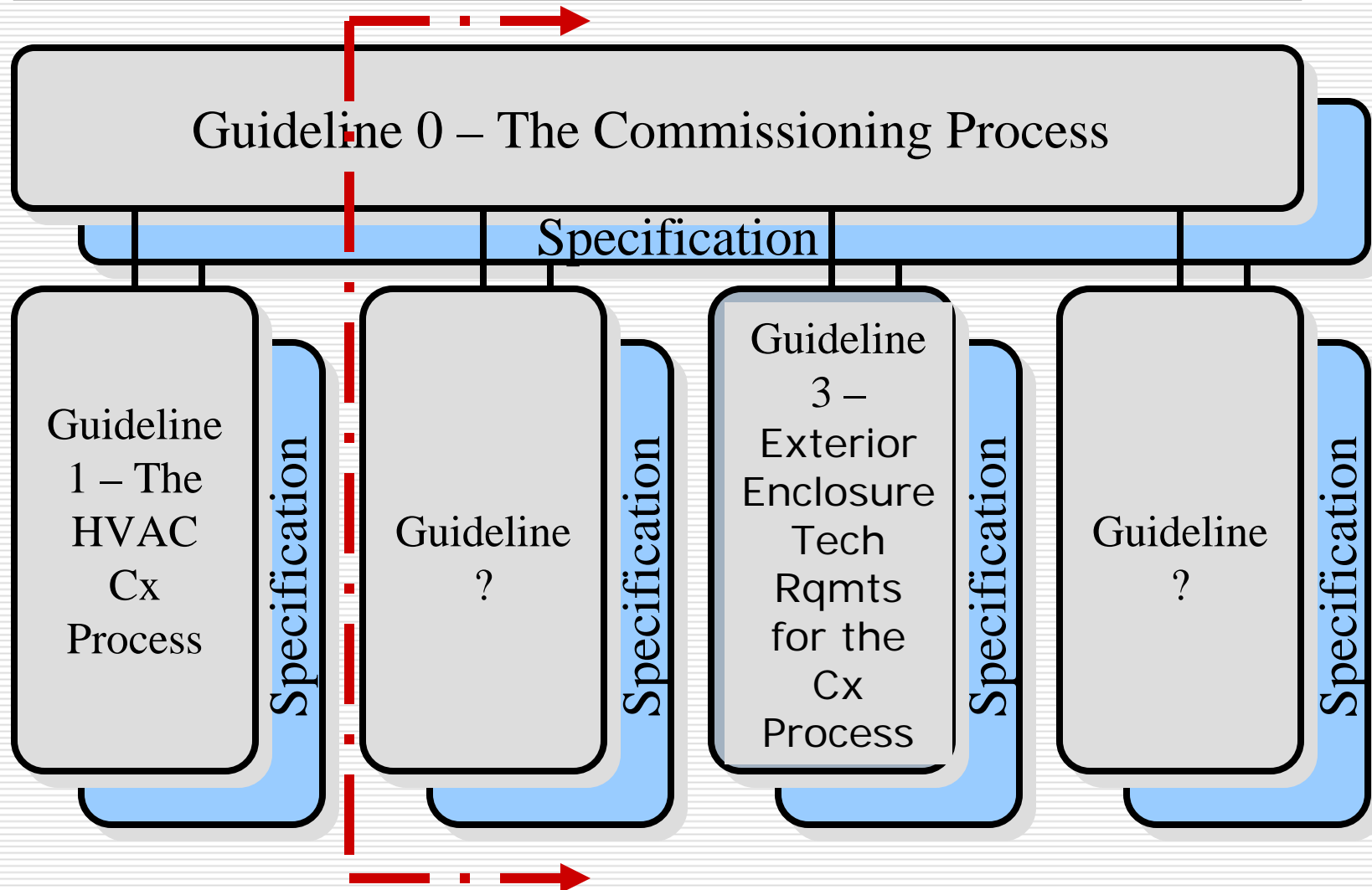

GUIDELINES RELATIONSHIP

Includes only construction and post-construction phase activities

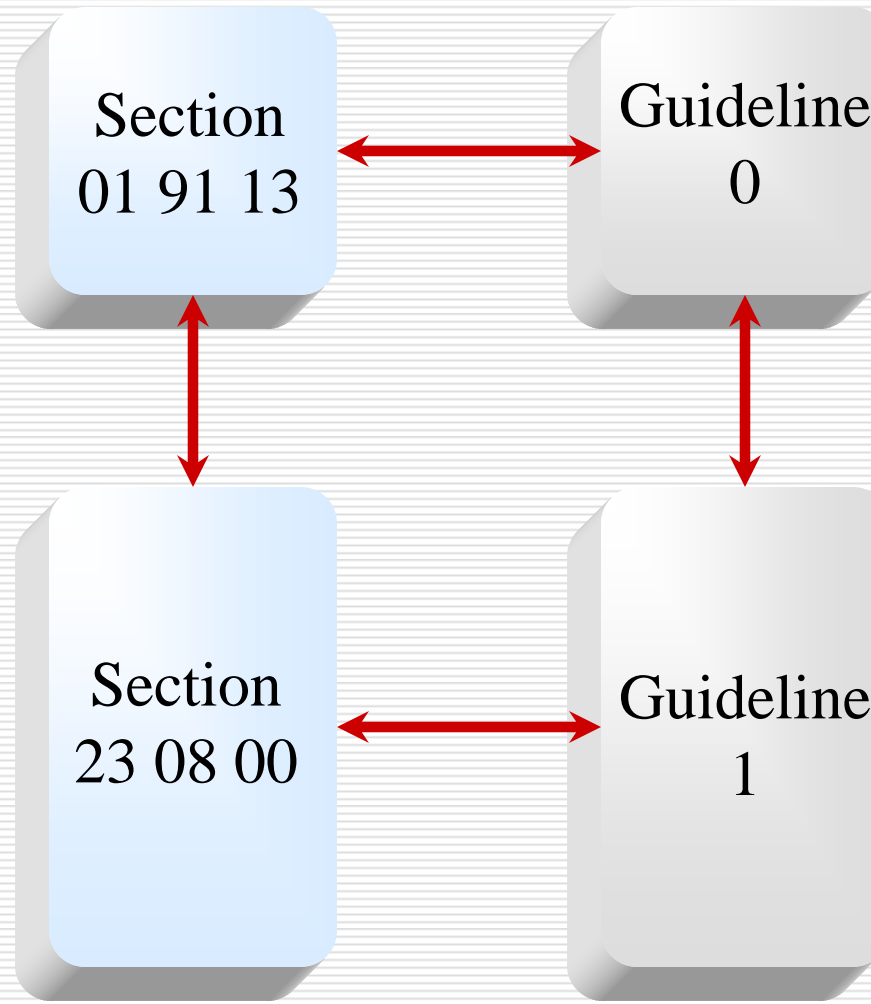

Includes all project delivery phases activities

Currently Published Guidelines

- ❑ Guideline 0 – The Commissioning Process
 - ❑ Guideline 1 – The HVAC Commissioning Process
 - ❑ Guideline 3 – Exterior Enclosure Technical Requirements for the Commissioning Process
-

Specifications Assumptions

- ❑ CxA should be a separate prime contractor
 - ❑ CxA should be a registered professional
 - ❑ Construction specifications include only construction phase tasks to be performed by the contractor
 - ❑ Each technical specification section will include only FQC
 - ❑ Commissioning sections will include systems integration testing
 - ❑ CxA should contribute to specifications
-

To sort
all this
out:



Let's
review
contracting
entities
and how
they relate
to each
other

Contracting Entities

- Owner
 - Design professional and Consultants (A/E)
 - Commissioning Authority
 - Contractor and Subcontractors
 - Equipment and systems manufacturers
-

Tripartite Relationship

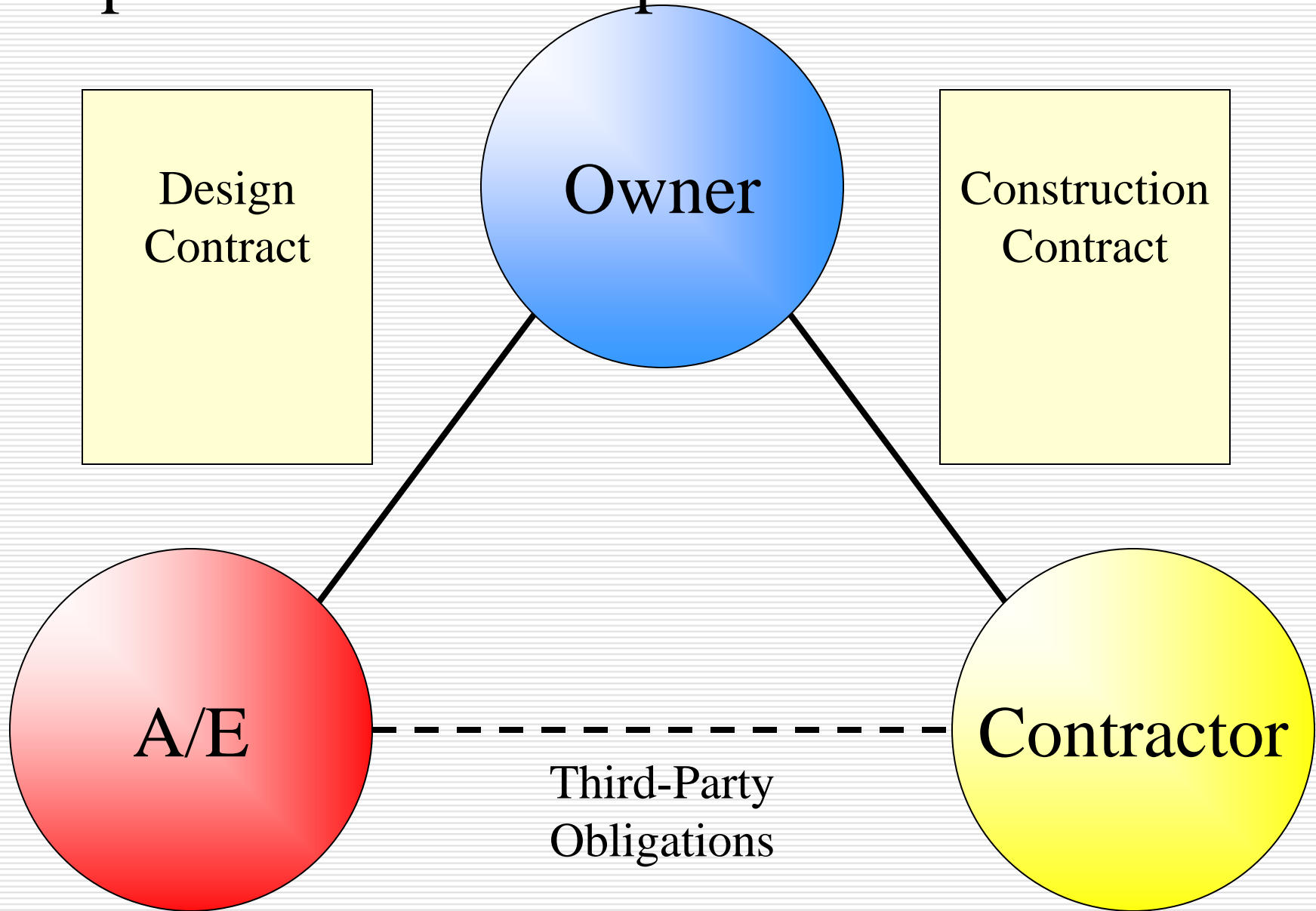

Tripartite Relationship

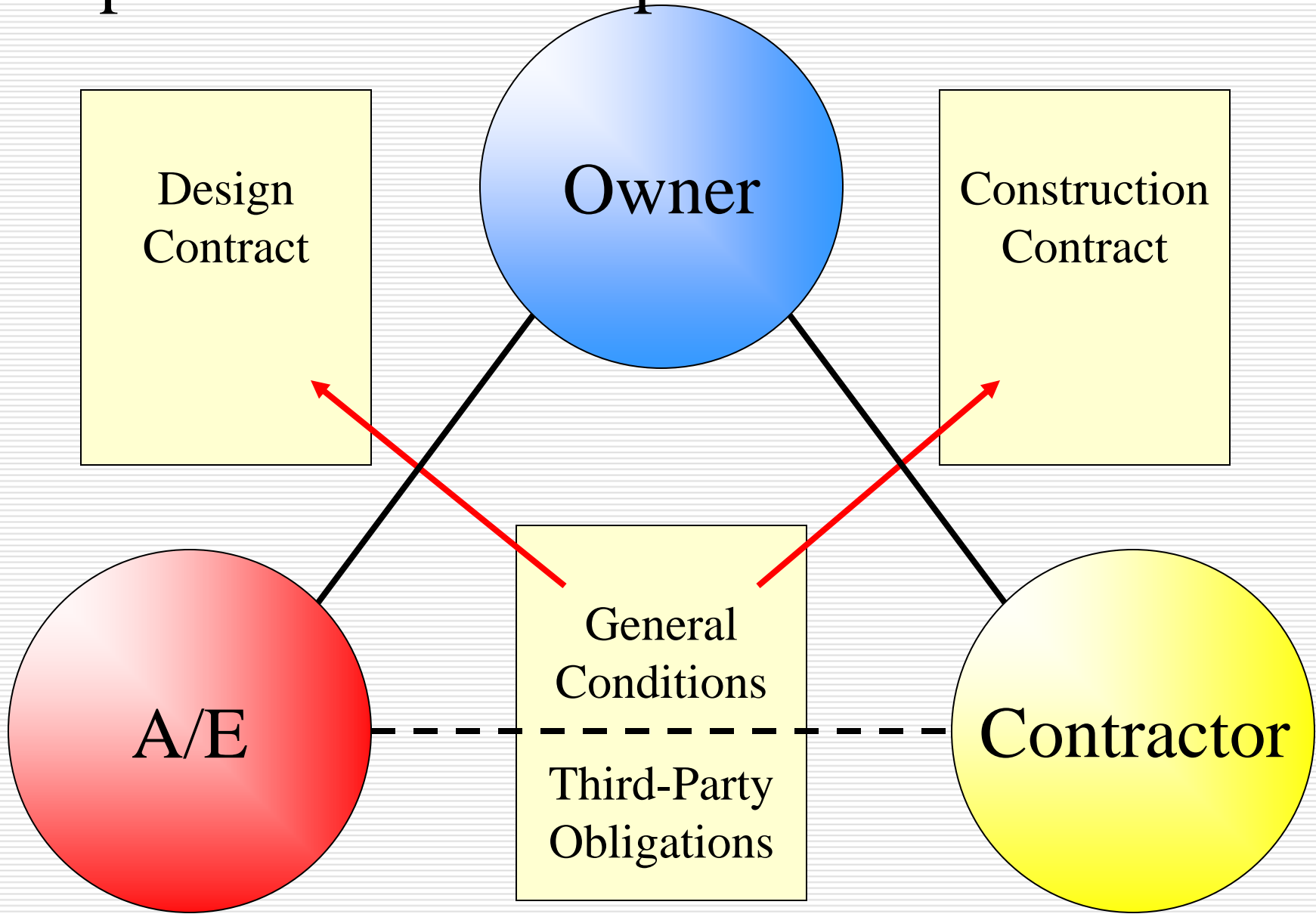

With CxA Added

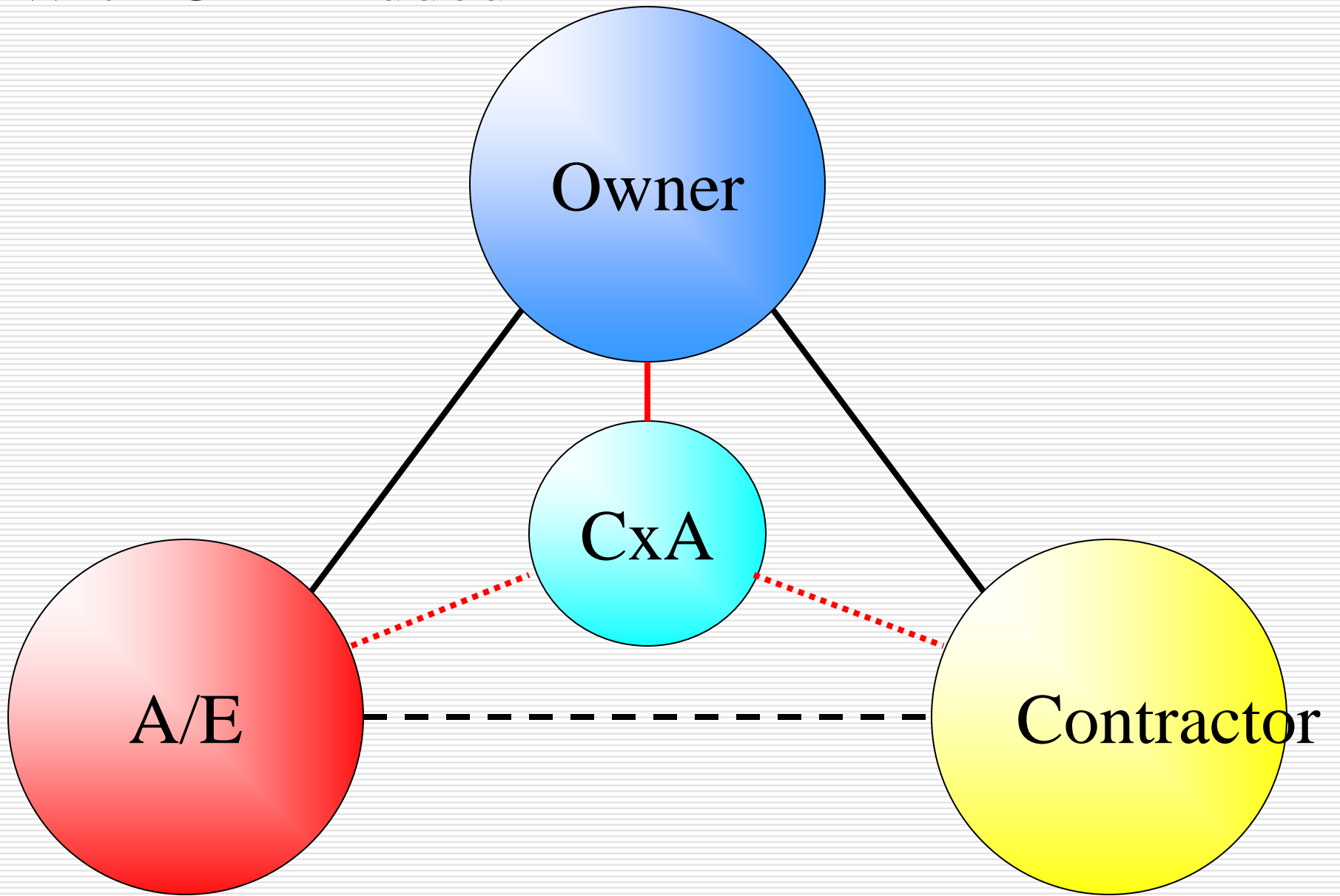

Owner-A/E Cont

Owner-CxA Contract

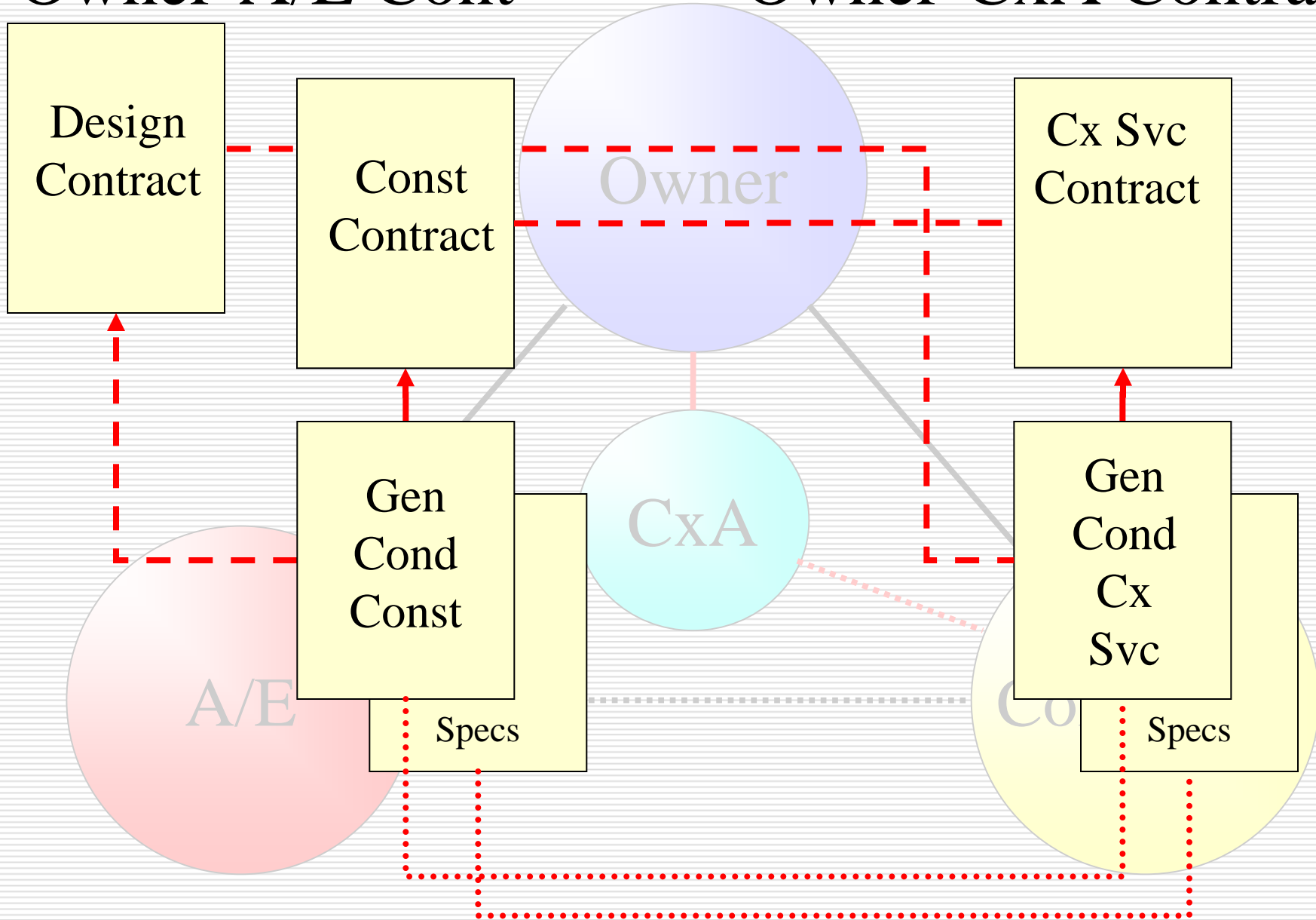

Two sets of Procurement and Contract Requirements

Commissioning Contr. Docs.

Procure-
ment &
Contract
Rqmts
for CxA

Specs
for CxA

Construction Contr. Docs.

Procure-
ment &
Contr
Rqmts
for
Const

Specs
for
Const

**Form of
Agreement**

**Conditions of the
Contract**

**Division 1 General
Requirements**

**Divisions 2-49
Specifications**

**Construction
Contract
Documents**

DRAWINGS

M1

**Form of
Agreement**

**Conditions of the
Contract**

**Division 1 General
Requirements**

**Divisions 2-49
Specifications**

**Commissioning
Contract
Documents**

DRAWINGS

M1

Commissioning Services Procurement and Contract Requirements

Commissioning Services

- Procurement Requirements
 - Contracting Requirements
 - Specifications
 - Drawings
-

Procurement Requirements

- Advertisement for Bids for Commissioning Services
 - Invitation to Bid for Commissioning Services
 - Request for Proposals for Commissioning Services
 - Request for Qualifications for Commissioning Service Providers
 - Instructions to Bidders for Commissioning Services
 - Commissioning Services Bid Forms
-

Contract Requirements

- ❑ Standard Form of Agreement between the Owner and Commissioning Services Provider
 - ❑ General Conditions of the Contract for Commissioning Services
 - ❑ Supplementary Conditions for the Contract for Commissioning Service
-

Commissioning Specifications

- ❑ 01 11 83 – Summary of Work for Cx Services
 - ❑ 01 26 93 – Cx Services Contract Modifications
 - ❑ 01 29 83 – Cx Services Contract Payment Procedures
 - ❑ 01 31 83 – Cx Team Meetings
 - ❑ 01 32 83 – Cx Plan
 - ❑ 01 32 86 – Cx Progress Documentation
 - ❑ 01 32 89 – Cx Issues Log and Reporting Requirements
 - ❑ 01 32 91 – Cx Forms
-

Commissioning Specifications

- ❑ 01 32 93 – Construction Checklists Requirements
 - ❑ 01 32 96 – Cx Acceptance Requirements
 - ❑ 01 33 83 – Cx Process Submittal Procedures
 - ❑ 01 43 26 – Testing Agency Qualification
 - ❑ 01 43 29 – Special Inspector Qualifications
 - ❑ 01 52 13 – Field Offices and Sheds
 - ❑ 01 78 83 – Systems Manuals
 - ❑ 01 79 00 – Documentation and Training
-

Summary of Work for Commissioning Services

- ❑ Roles and responsibilities of the CxA, Owner, and design professionals.
 - ❑ Requirements to develop the Owner's Project Requirements (OPR), including an OPR workshop
 - ❑ Requirements for development of commissioning plan
 - ❑ Requirements for development of commissioning specifications (for the construction contract documents)
-

Summary of Work continued

- ❑ Requirements for development of testing procedures and construction checklists
 - ❑ Requirements for development of systems manual
 - ❑ Requirements for development and execution of a owner's maintenance and operations personnel training plan
-

Revisions to Design Agreements

- Need to revise A/E design services agreement to include additional services required for commissioning processes
 - Additional activities
 - Do NOT supplant professional responsibilities
-

Way Forward

- Collaborative work among multiple organizations
 - Draft documents and get public review and comment
 - Make readily available and easily accessed
-

Needs and Solutions for Documenting Commissioning

Michael J. King, FCSI, CCS, MAI
Vice President of Engineering Specifications
ARCOM – Publishers of MASTERSPEC

(800) 200 6652
mking@arcomnet.com

