



Retro-commissioning (RCx) Sustainable Savings: Are We There Yet?

N. "Amar" Amarnani
&
Brian Roberts

County of Los Angeles - ISD

NCBC Chicago, May 2-4, 2007



Retrocommissioning (RCx) Partnership & Project Funding



 Funded by California Public Utilities Commission

 Partnership members

 Southern California Edison

 Southern California Gas





 County of Los Angeles

 11 Facilities (1.6 million GSF) retro-commissioned

 Facilities maintained and operated by Internal
Services Dept, County of Los Angeles













RCx Project - Defined Goals

-  Optimize operations of Heating, Ventilation and Air Conditioning (HVAC) systems in the County buildings
-  Identify optimization and energy efficiency measures
-  Improve thermal comfort, ventilation and indoor air quality in the County buildings
-  Develop tool for sustainable reduction of electricity and natural gas
-  Provide operations staff with comprehensive facility information, update methods to efficiently operate, maintain and monitor HVAC systems



Defined Project Tasks

-  Whole building energy benchmarking
-  Diagnostic measurements
-  Prefunctional testing of individual components
-  Minor HVAC system repairs
-  Building automation improvements
-  Functional Performance Testing of HVAC systems
-  Install new optimization energy efficiency measures
-  Modeled energy savings projections
-  System level benchmarks
-  Retro-commissioning reports & schematics
-  Training manual

Adapted RCx Process

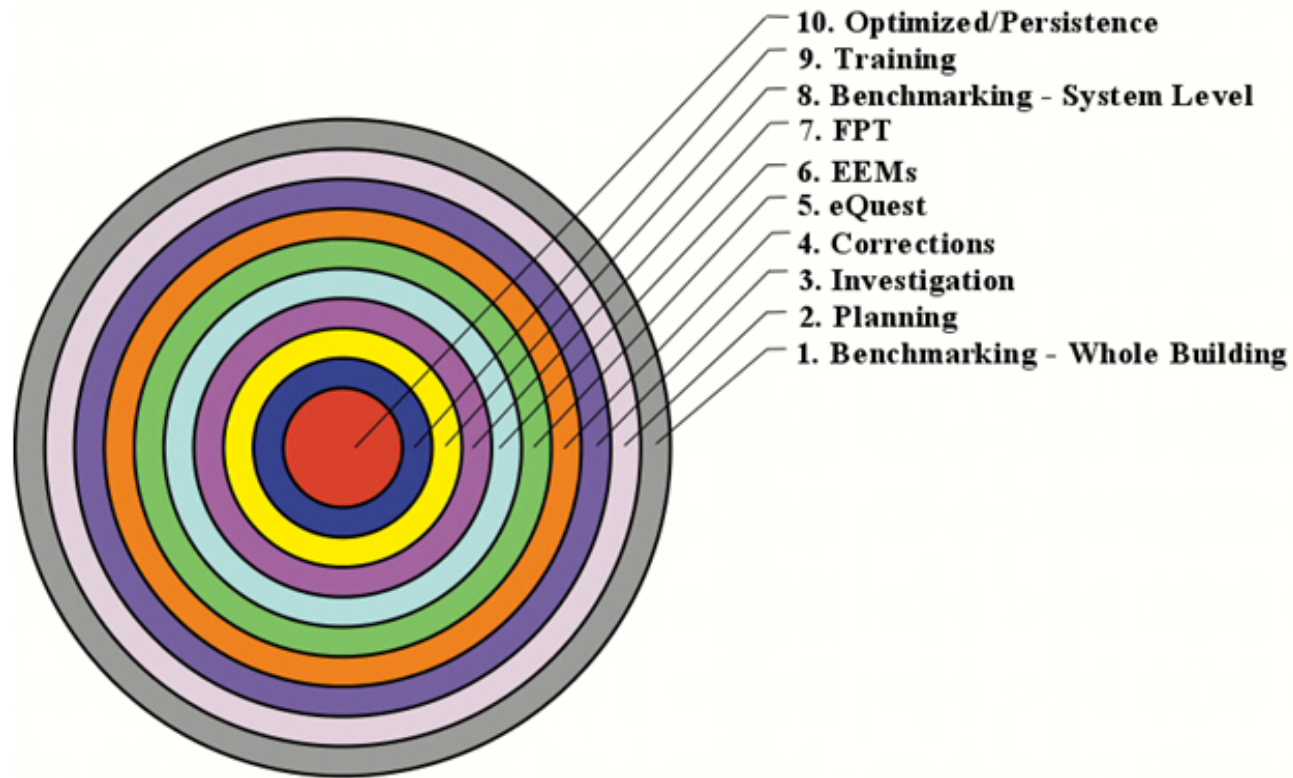











Figure 1. Retro-commissioning (RCx) process adapted by SCE/SCG/County of LA Partnership Program.



HVAC RCx Measures

-  Tested and calibrated all existing controls
-  Improved Chiller Sequencing
-  Installed customized Purge Cycles
-  Optimized Economizer Controls
-  Improved Boiler Combustion Efficiency
-  Installed Boiler Hot Water Reset Controls
-  Installed Discharge Air Reset Controls
-  Improved VAV Static Pressure Controls
-  Performed Diagnostic Air and Hydronic Testing
-  Selective air balancing and terminal box repairs

Energy Efficiency Measure Projected Savings

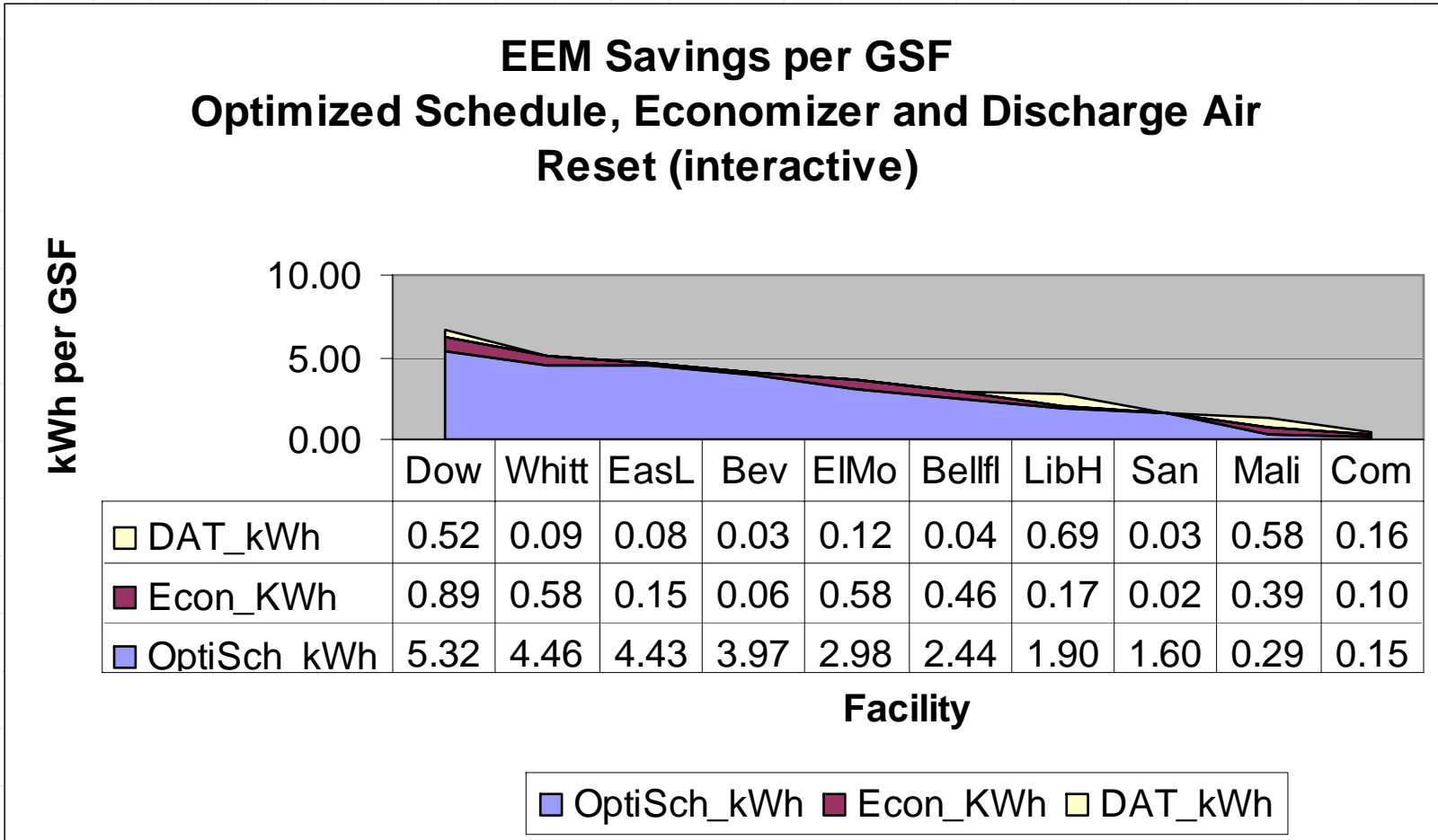



RCx Cost & Utility Savings per GSF

RCx Cost & Savings Indices

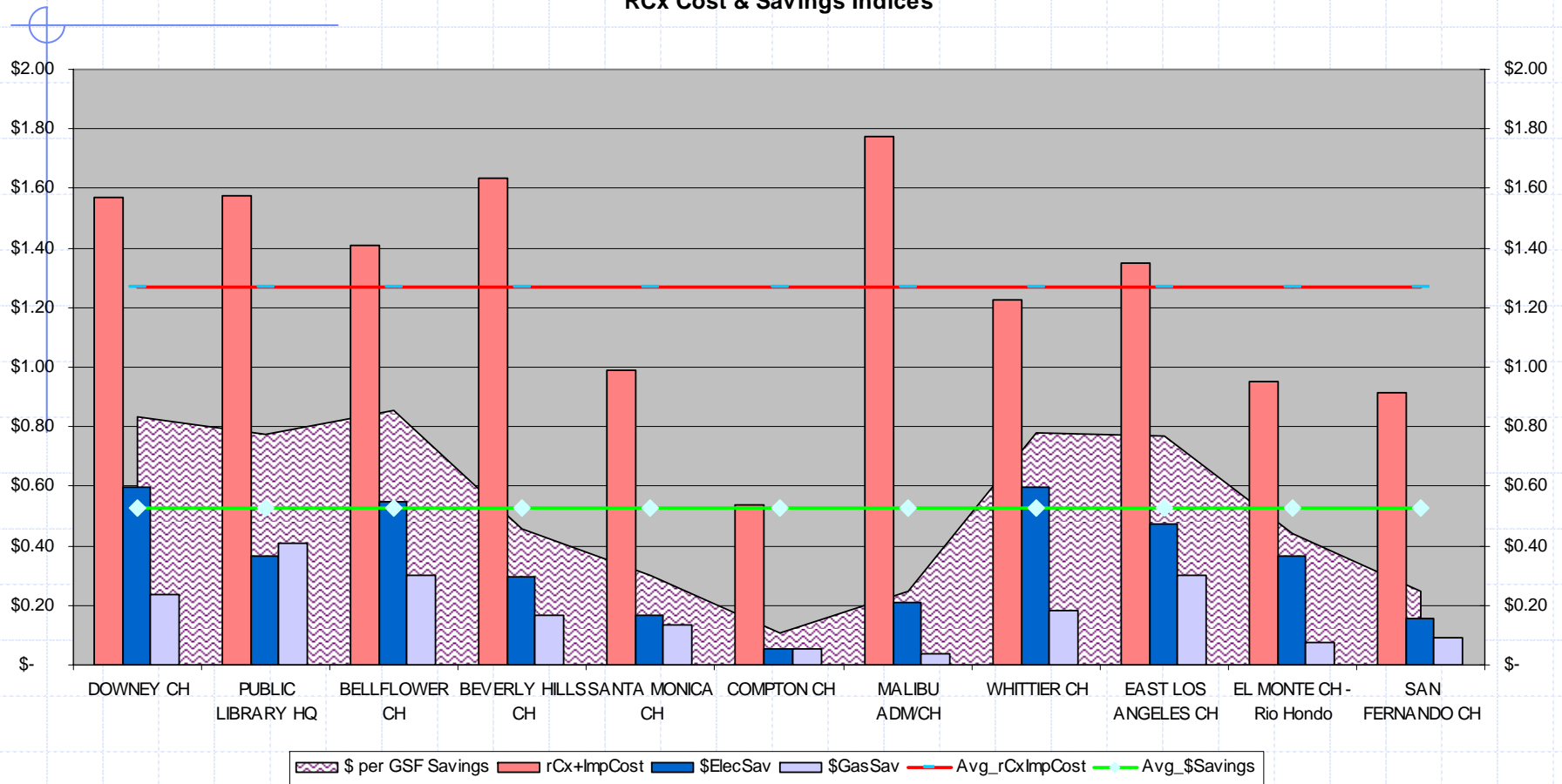

RCx Utility Savings

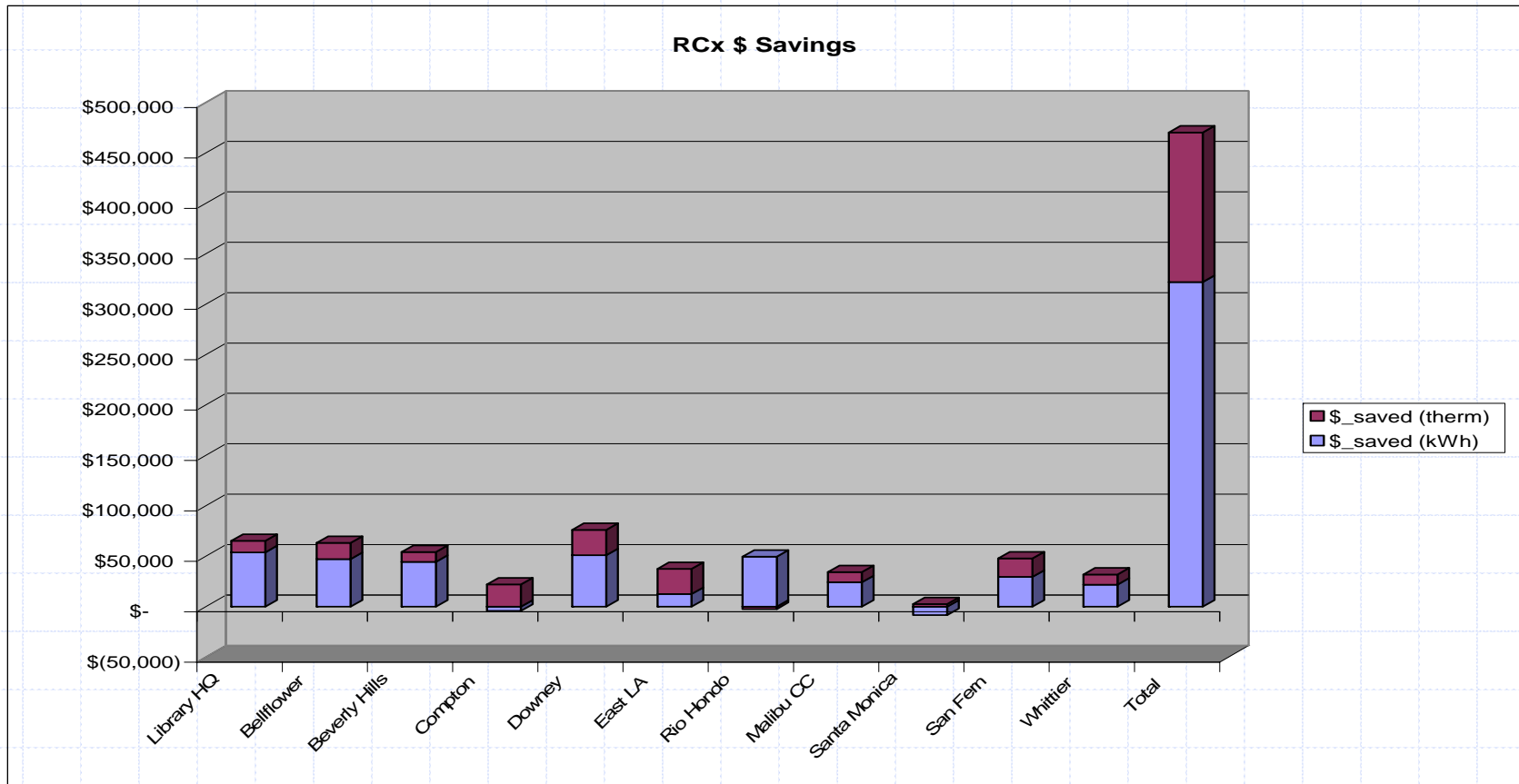

Figure 21: Post-RCx operational savings (\$).

RCx kWh Savings Against Baseline

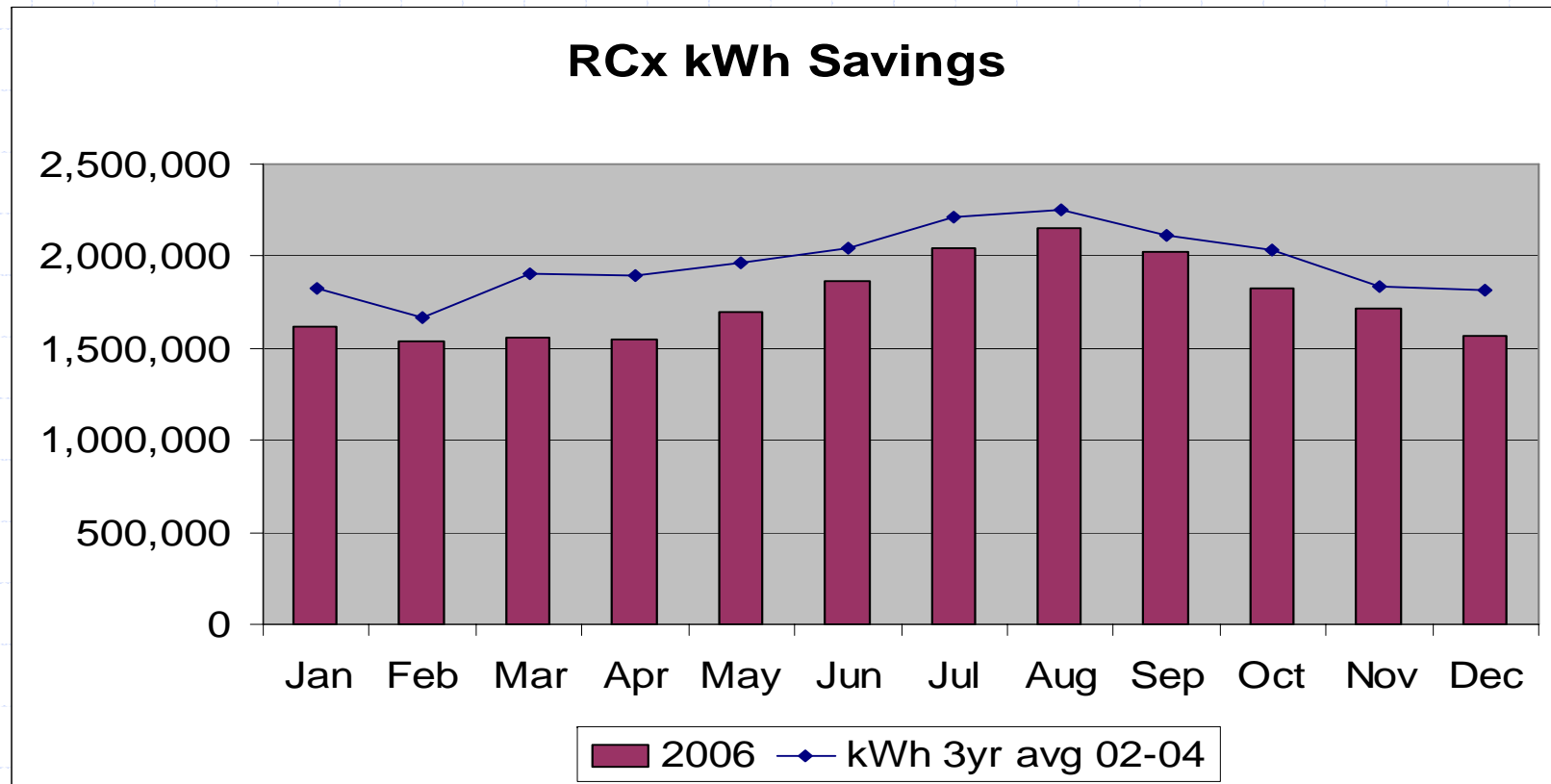

Figure 22: Post-RCx electric energy (kWh) savings.

RCx Therm Savings Against Baseline

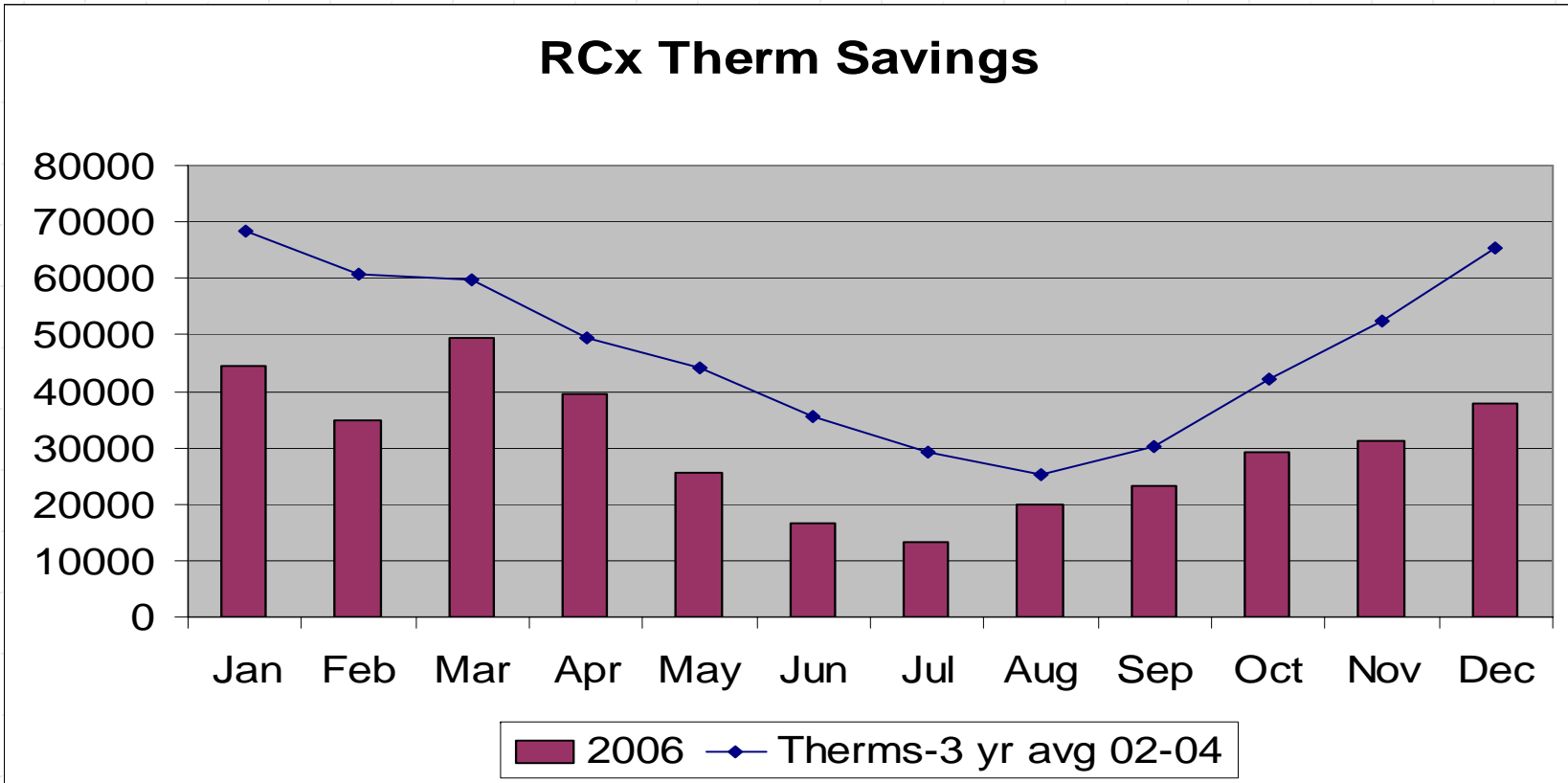

Figure 23: Post-RCx gas energy (therms) savings.

Post-RCx kWh EUI

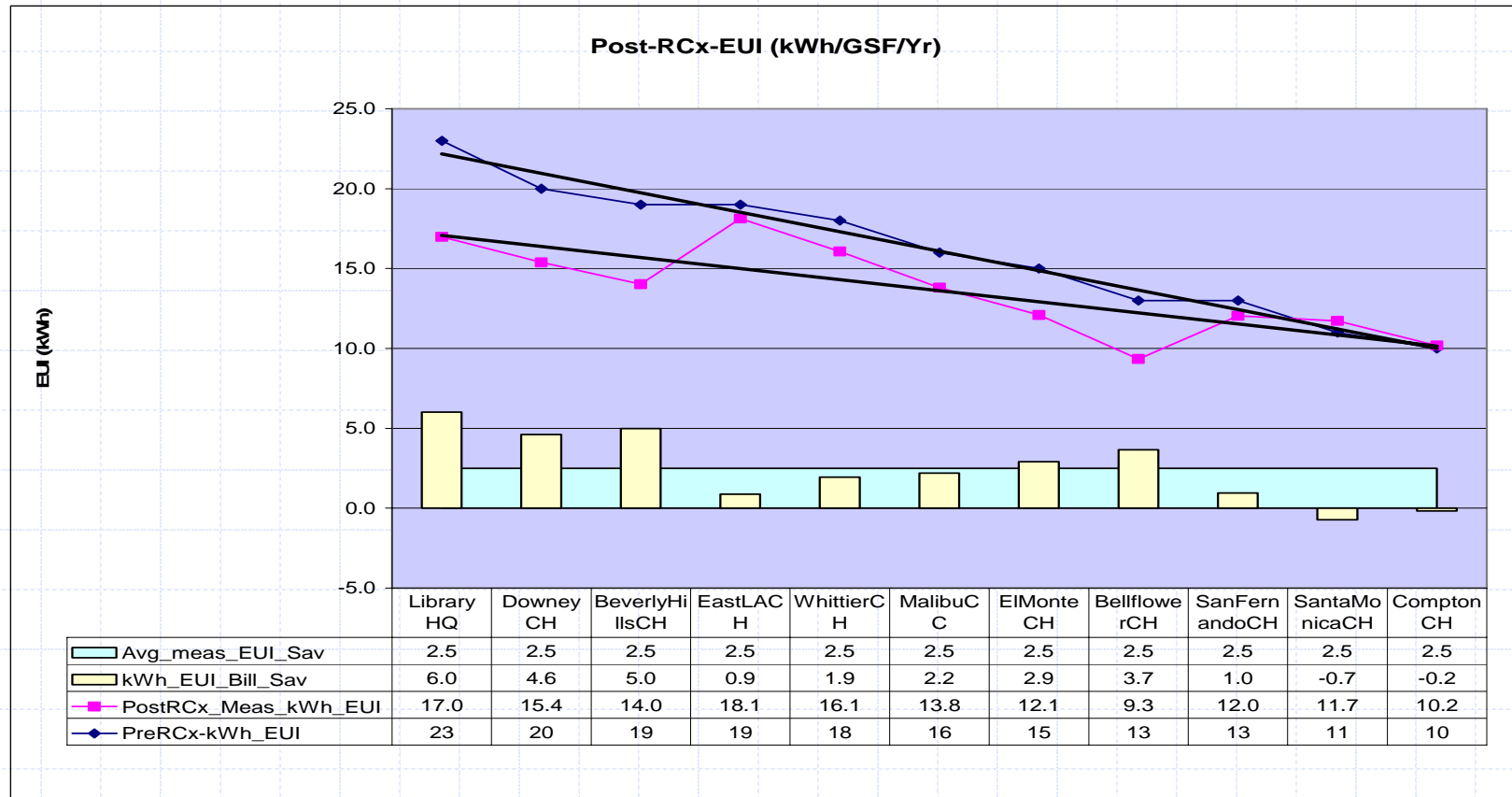
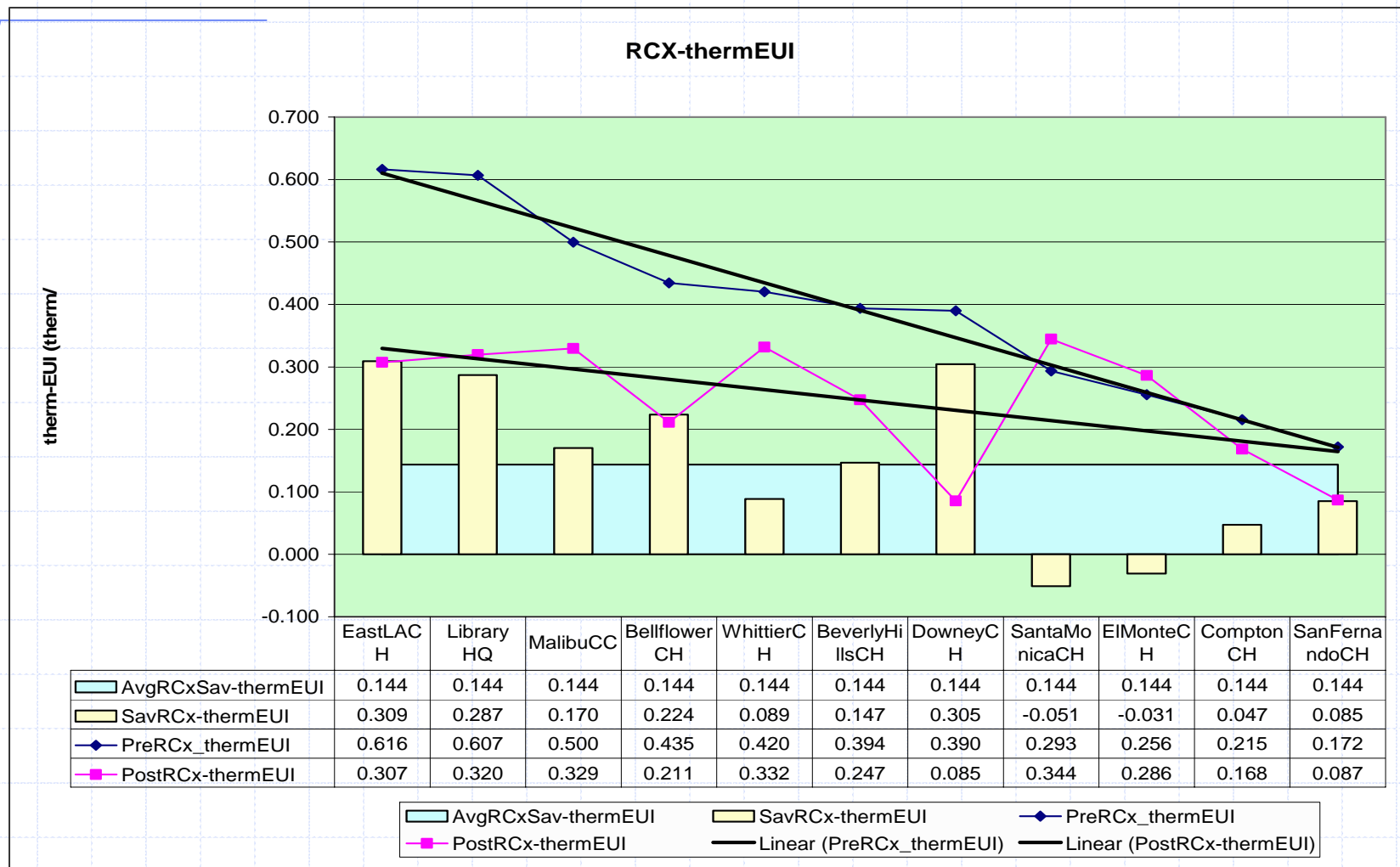



Figure 24: Post-RCx EUI (kWh).

Post-RCx Therm EUI



NCBC Chicago, May 2-4, 2007  Figure 25: Post-RCx EUI (therms)

L A County EEMIS Network

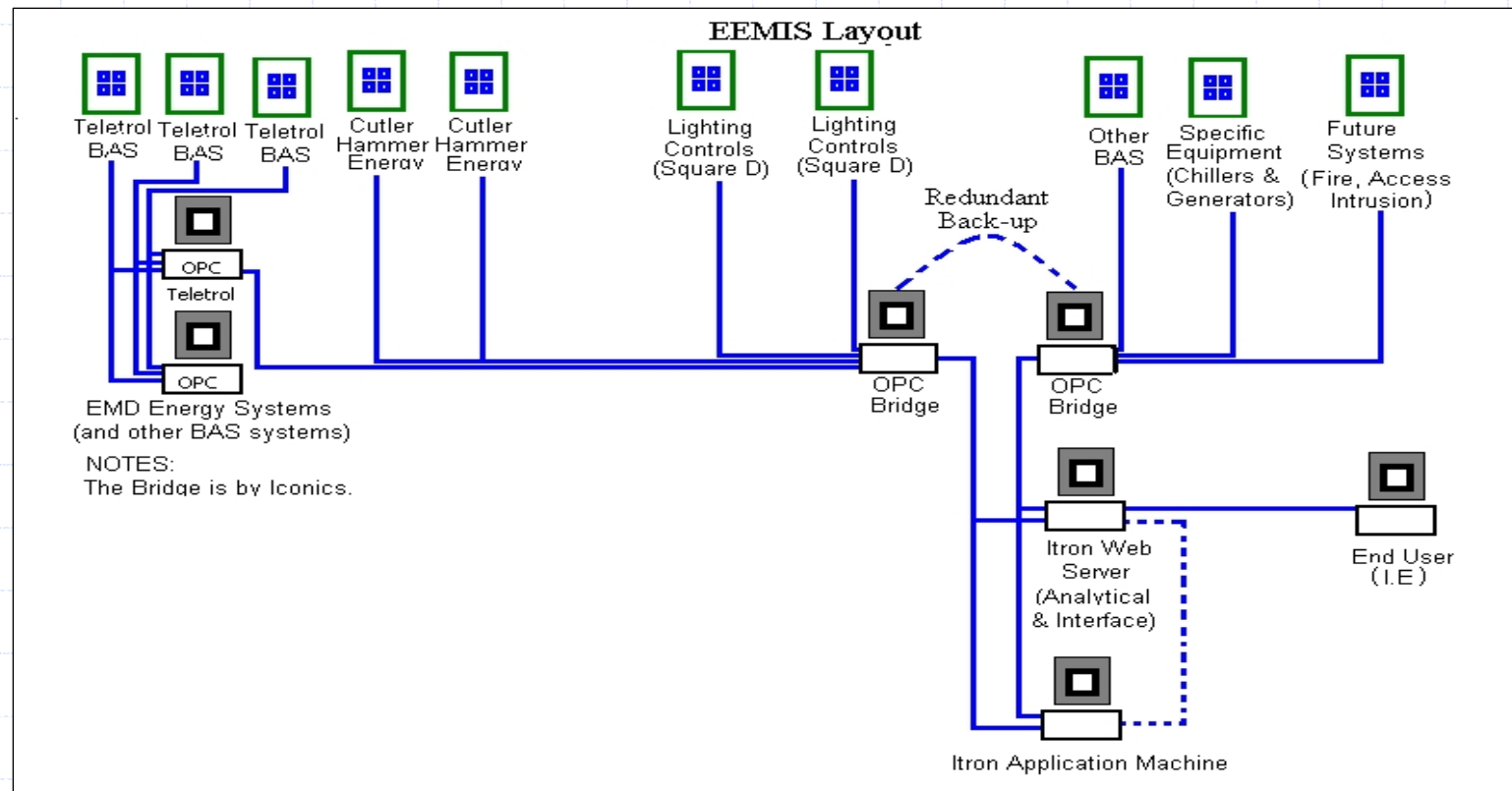

Figure 4: County of Los Angeles Enterprise Energy Management Information System (EEMIS) configuration.

RCx Sustainability Process

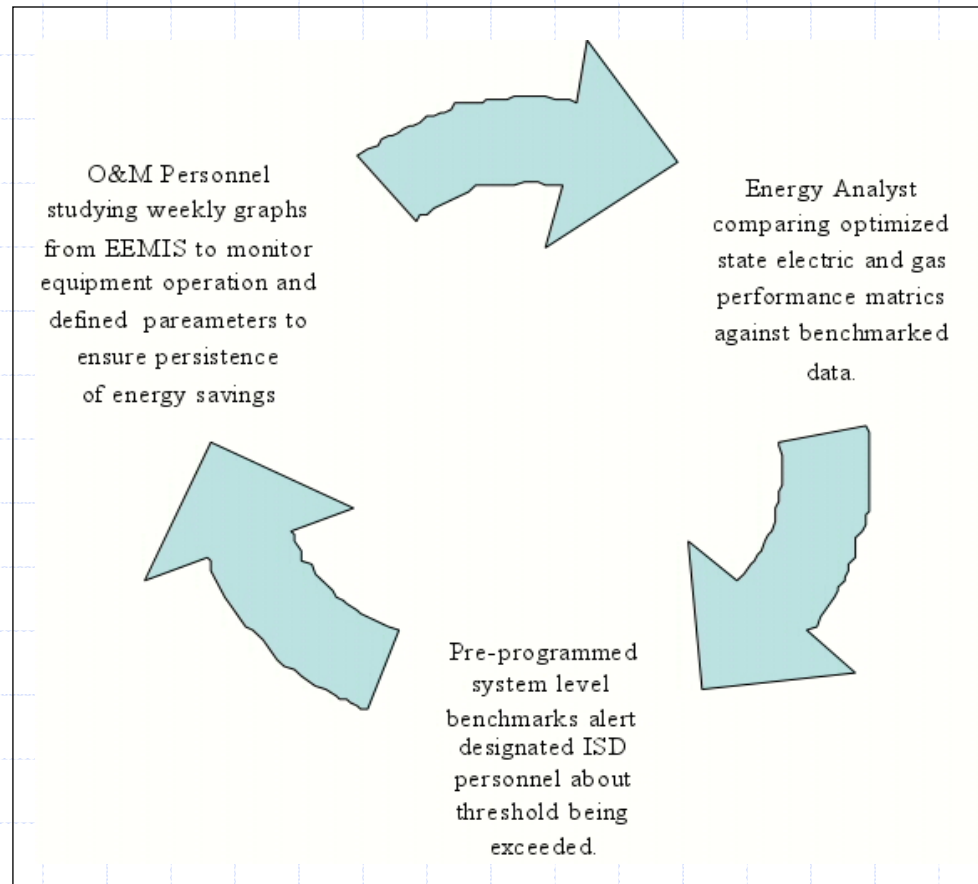





Figure 3: Three-prong approach for persistence of RCx savings.





RCx Sustainability Roadmap





Facility Monitoring

-  Ventilation
-  Cooling System
-  Heating System

Whole Building Energy Usage Analysis

-  Electric
-  Gas

System-level Benchmark Alerts

-  Ton-hours
-  Btu-hours
-  Run hours

Verification of Fan Operation

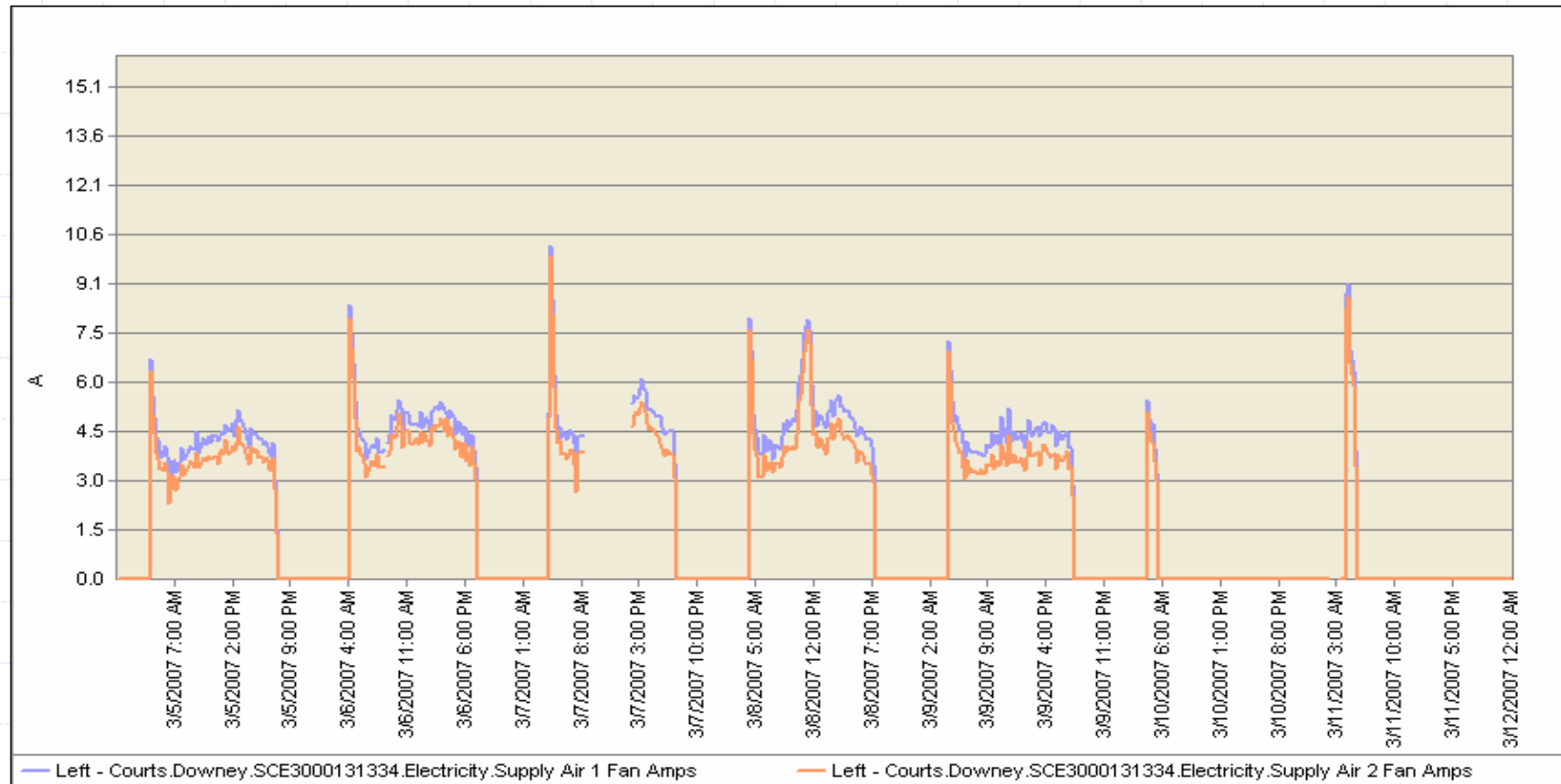
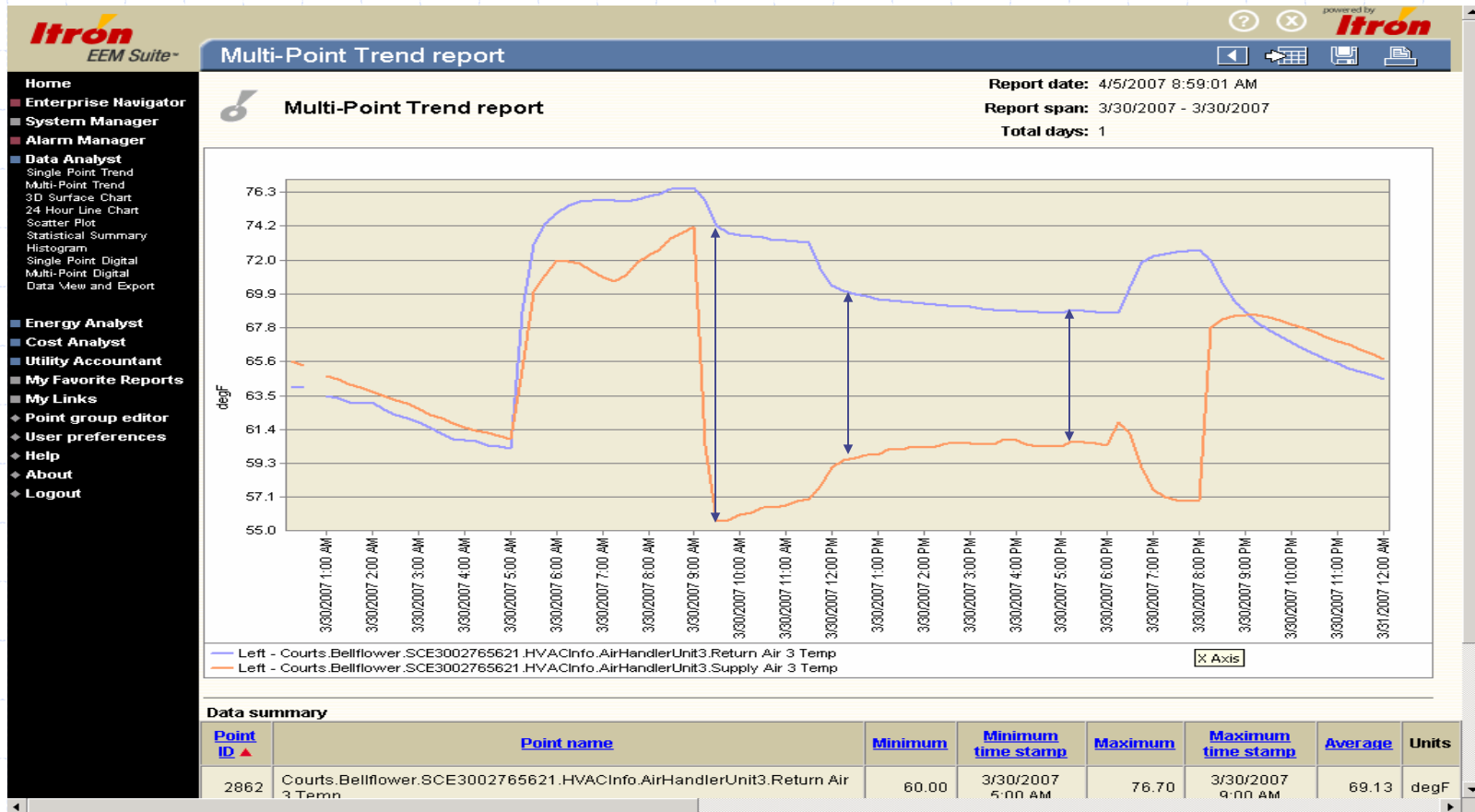

Figure 5: Weekly Fan Operation

Supply Air v. Return Air



53 Figure 8: Supply air vs. return air temperature.

Chiller Schedule

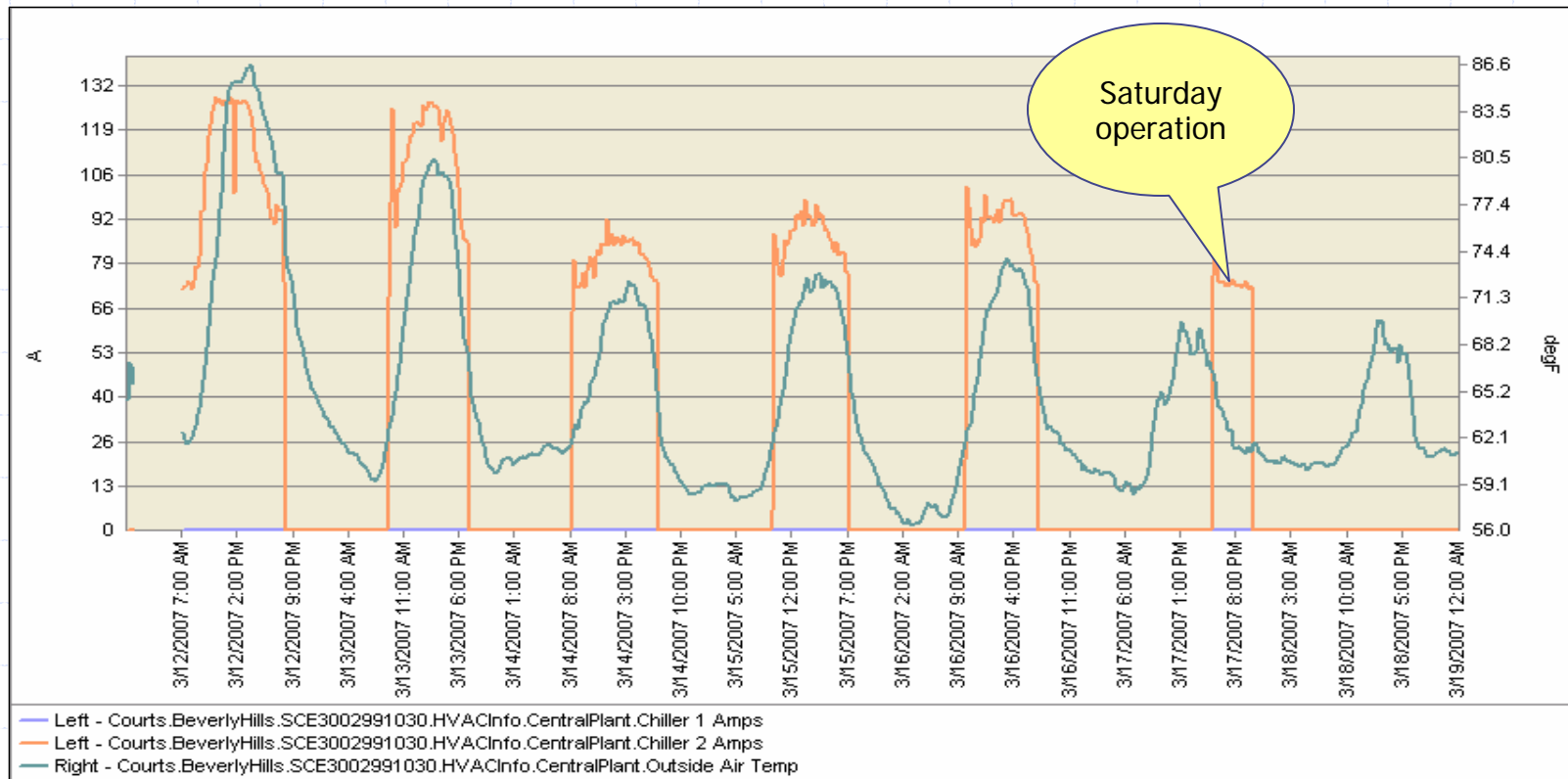

Figure 11: Chiller Operating Schedule.

Chiller OSAT Lock-out

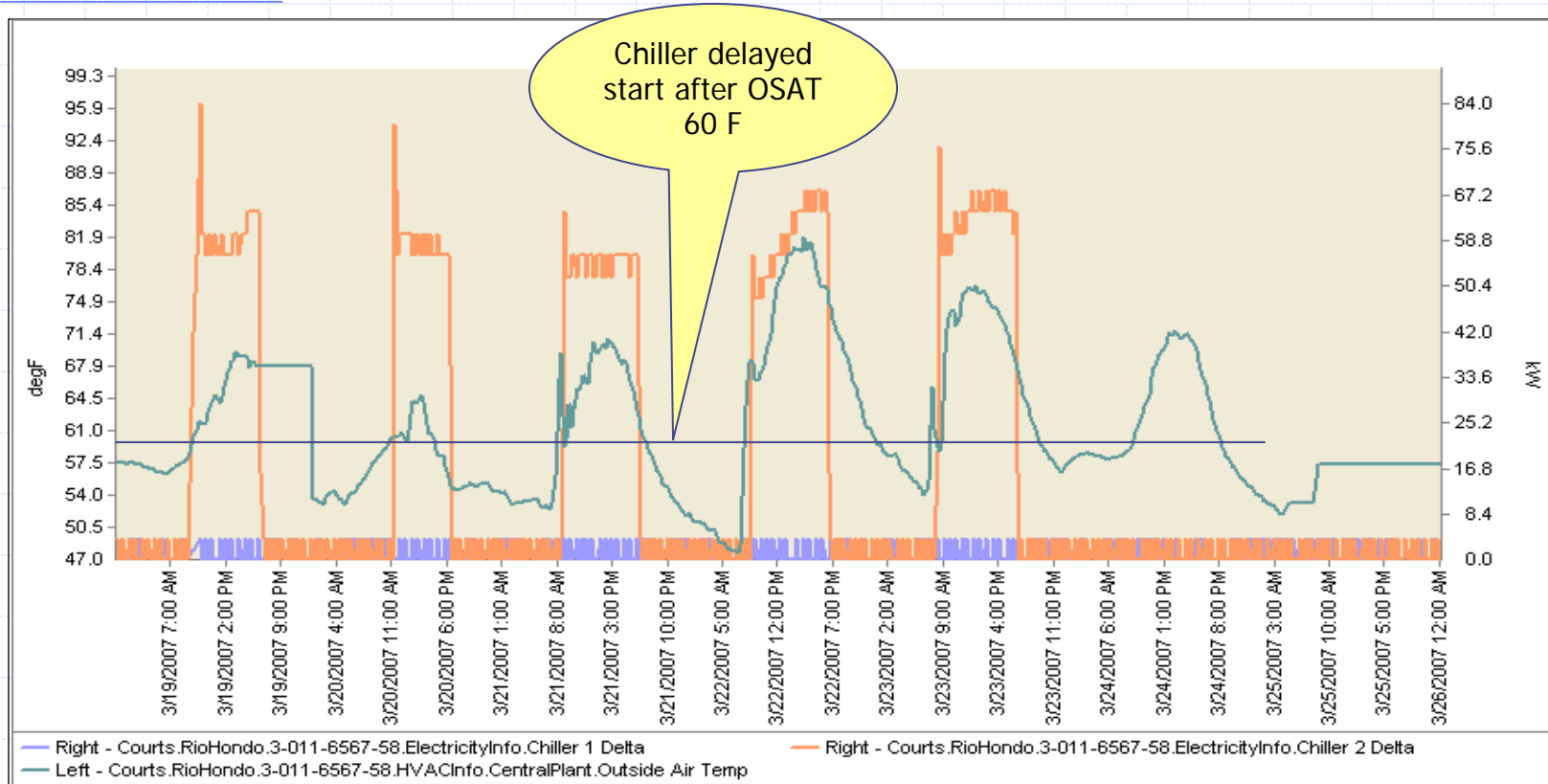

Figure 12: Chiller lock-out temperature verification.

Hot Deck Reset

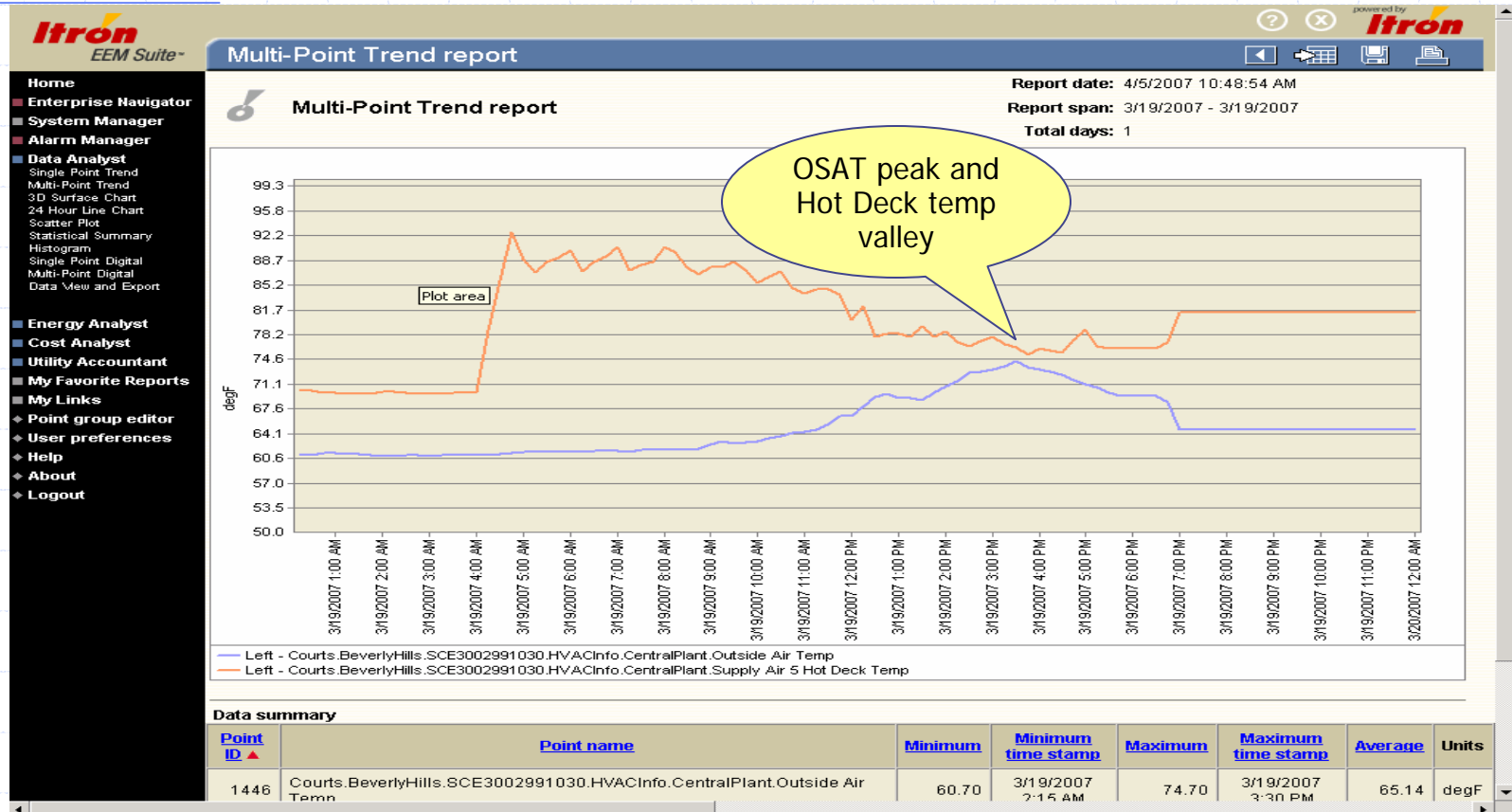

Figure 10: Hot deck temperature vs. outside supply air temperature.

HWST Reset

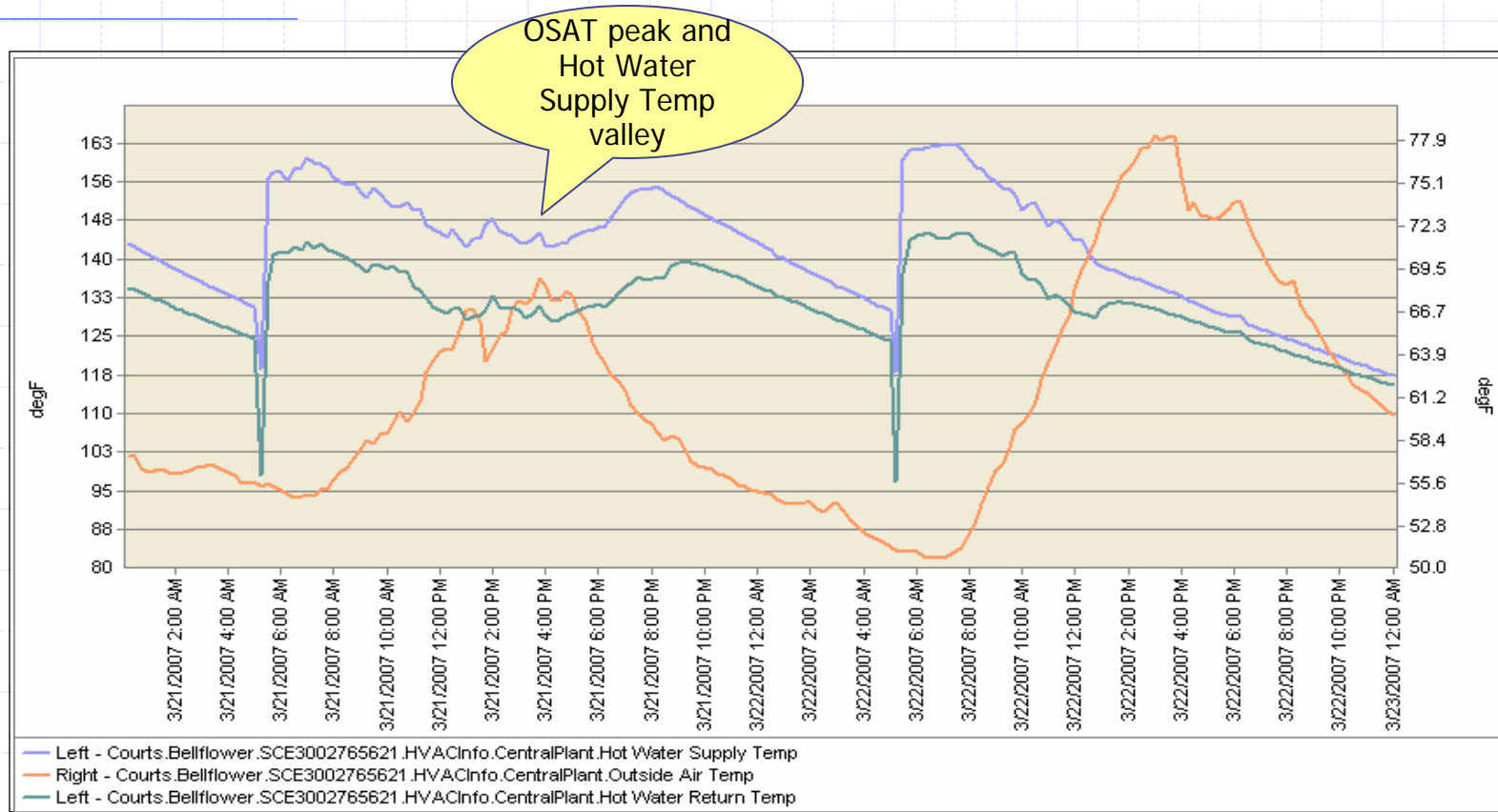

Figure 14: Verification of HWST reset based on OSAT

HWP OSAT Lock-out

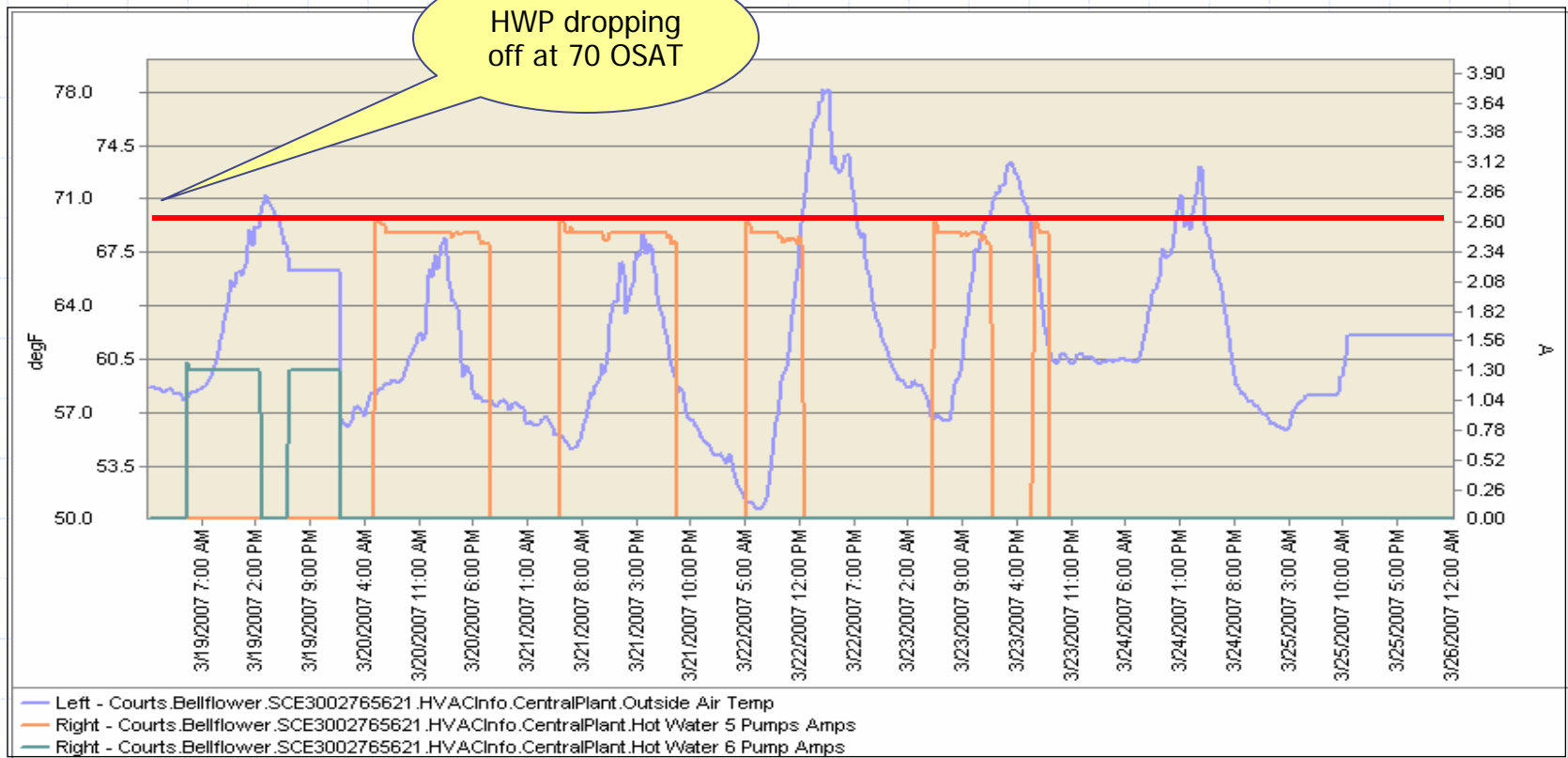

Figure 15: Hot water pump OSA lock-out.



Whole Building Energy, Demand

 Demand monitoring of whole building utility

 Weekday

 Weekends

 Night

 kWh Performance - Cumulative

 Monthly

 Annually

Utility Main

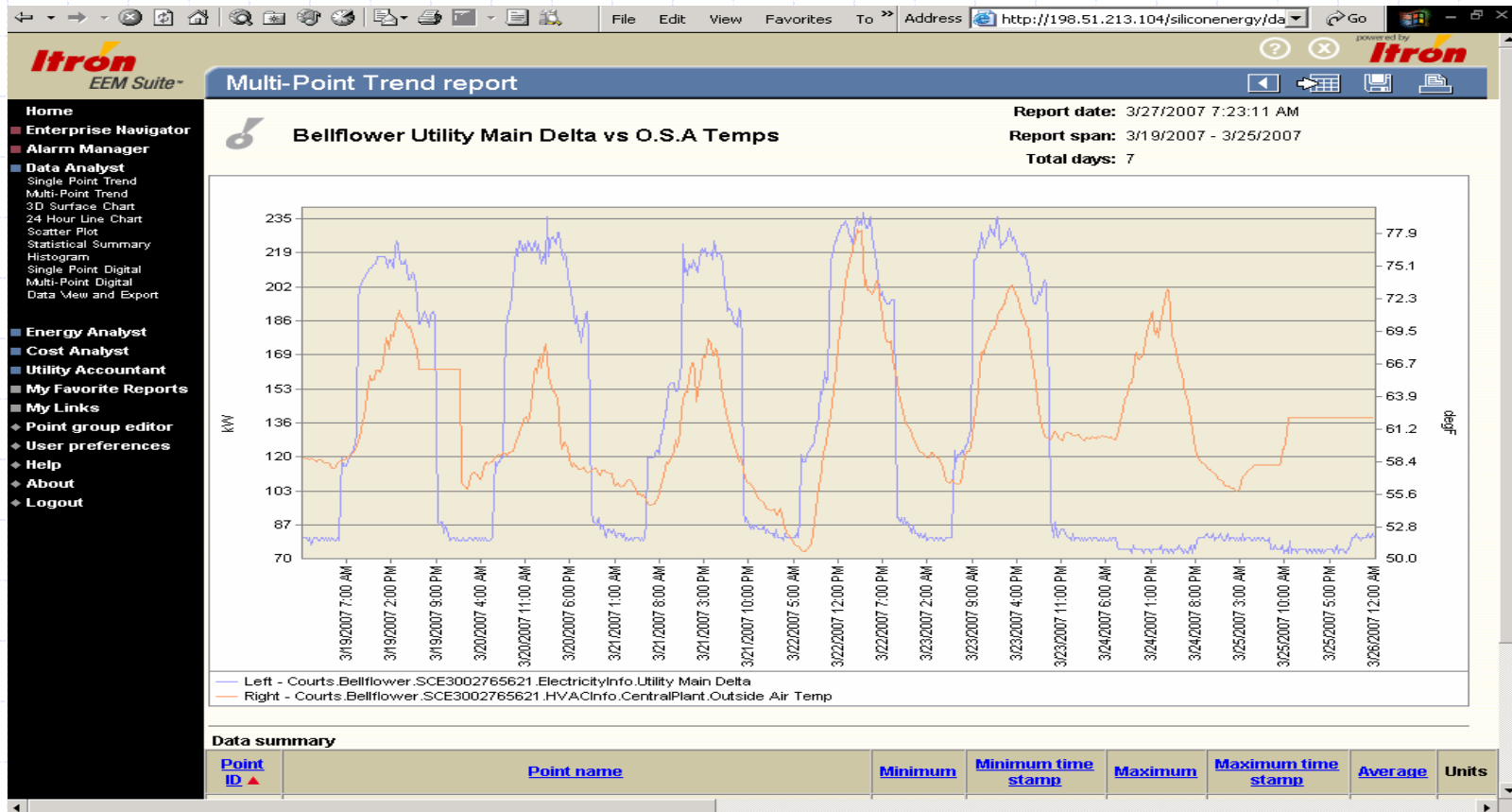

Figure 16: Building Demand (kW).

kWh Performance

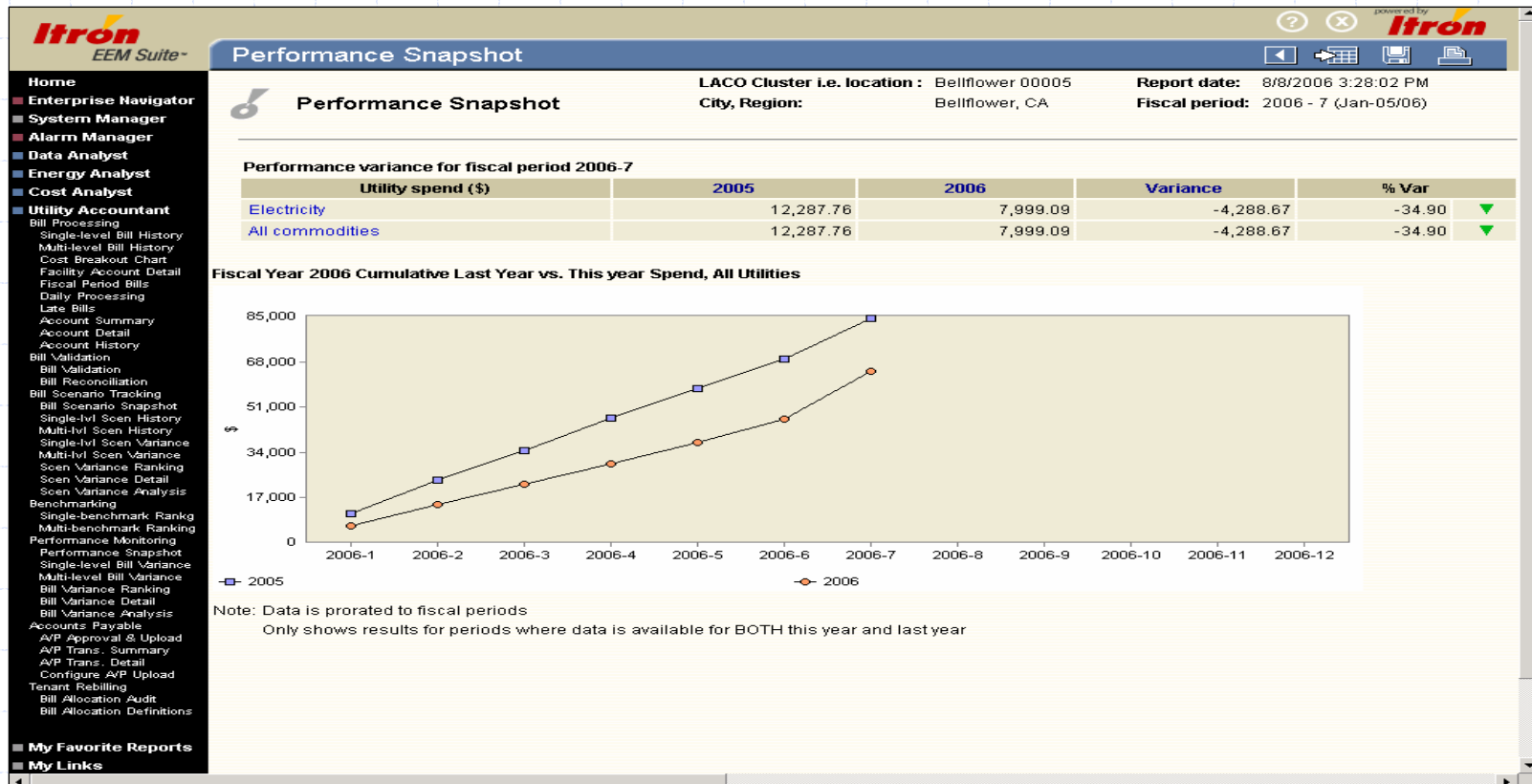









Figure 18: Whole building measured kWh consumption compared with benchmark.



System Level Benchmarks

-  Cooling System
 -  Chiller kW vs. OAT
 -  Ton-Hrs vs. OAT
 -  kWh vs. Ton-Hrs
-  Ventilation
 -  Fan kW vs. OAT
 -  Run-Hrs
-  Heating System
 -  Boiler Btu-Hrs

System-level Benchmark Tons Vs. OAT

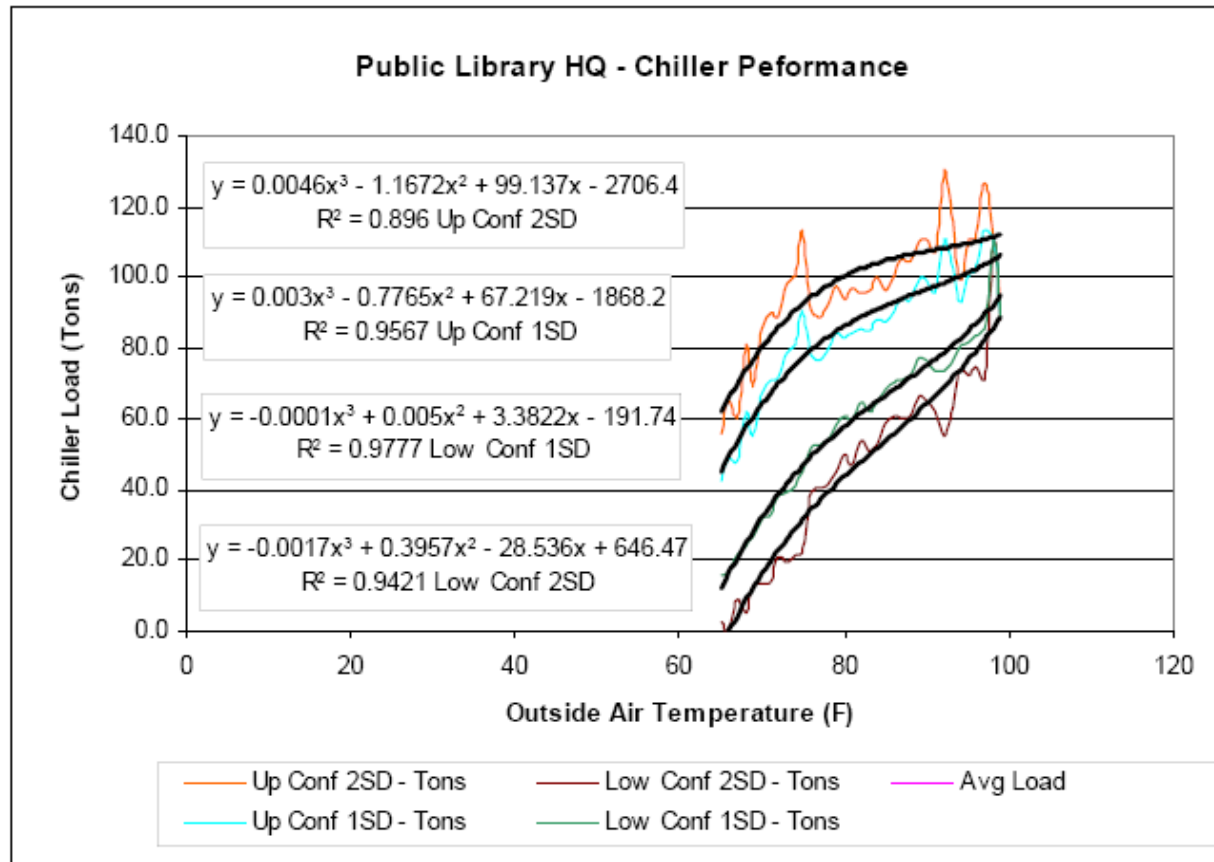

Figure 4-4. Chiller Load Performance – Representation with Equations

System-level Benchmarking EEMIS UCE+



RCx Persistence Process

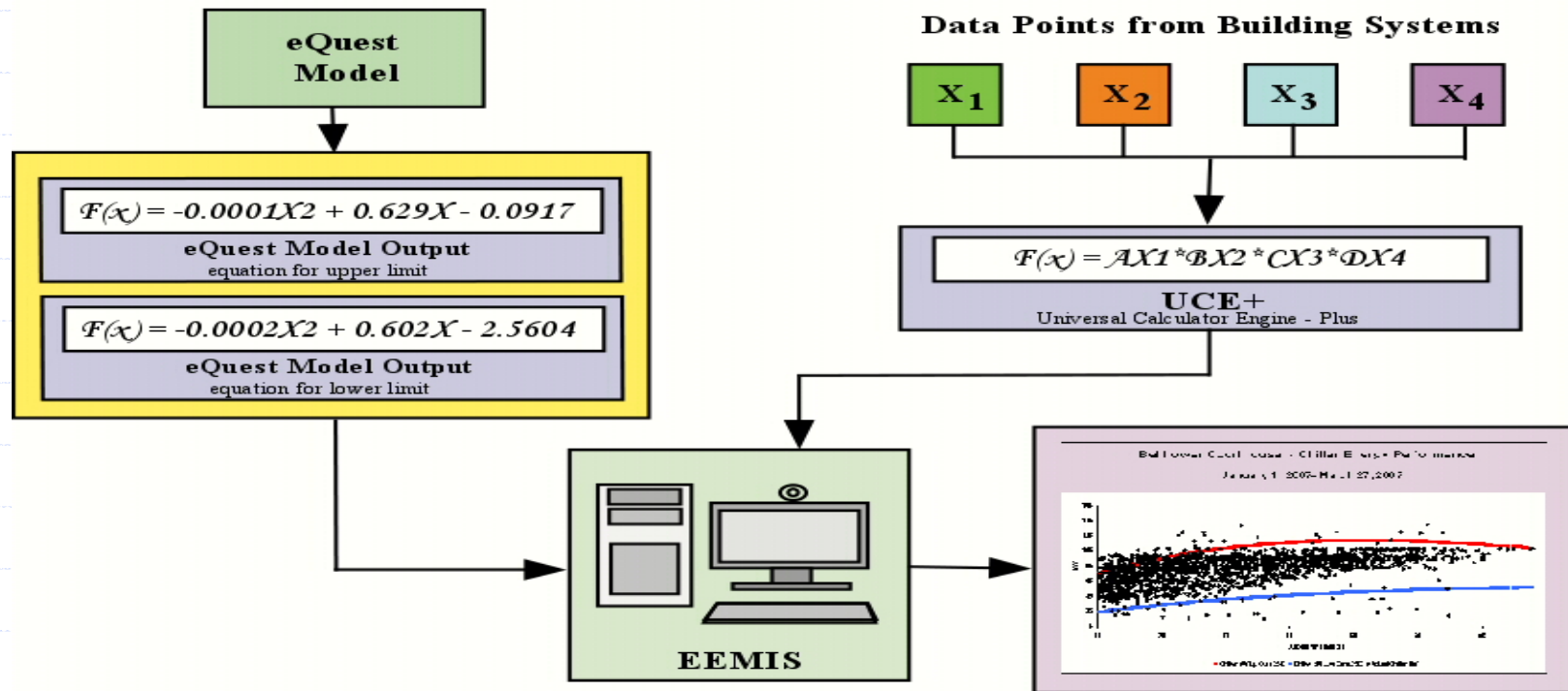

Figure 20: RCx persistence process utilizing Universal Calculation Engine Plus (UCE+).

Chiller Efficiency

kWh Vs. Cumulative Ton-hours

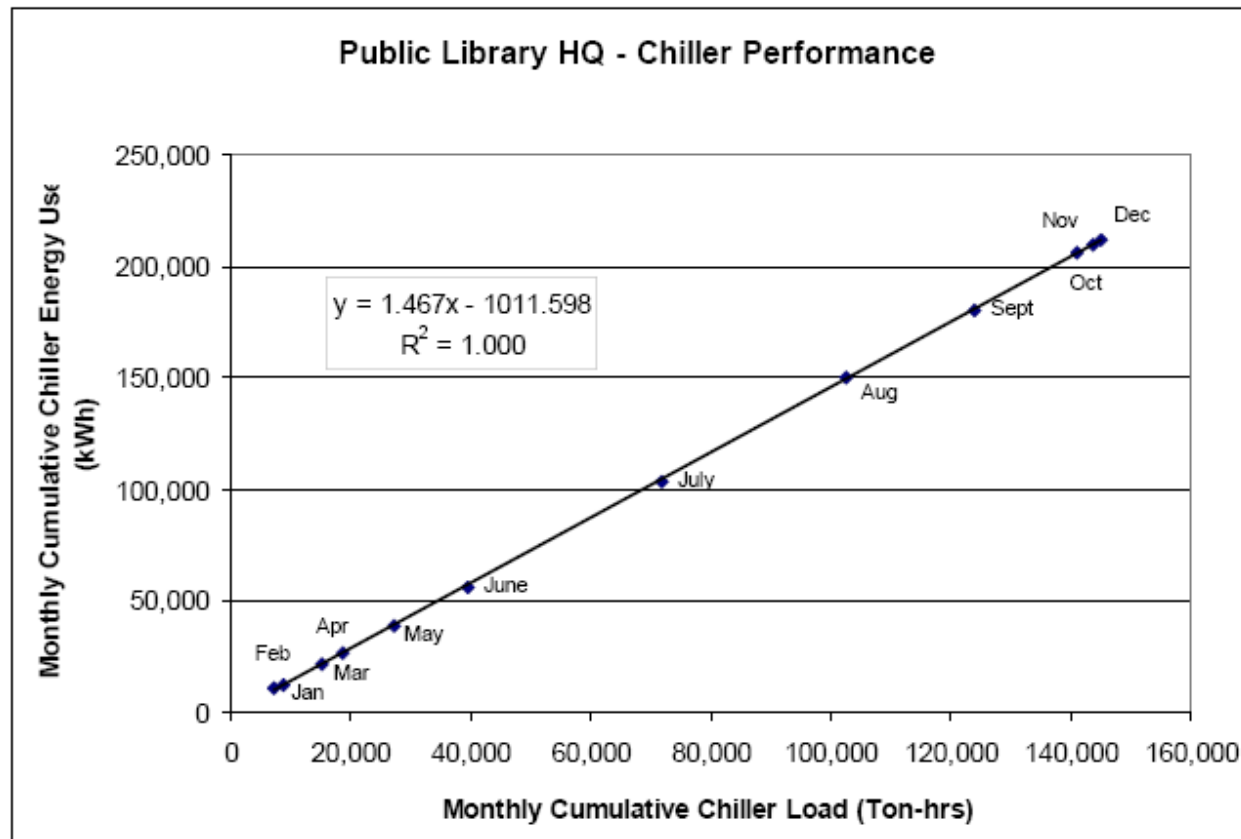





Figure 4-7. Monthly Cumulative Chiller Performance (kWh versus ton-hours)

Recap: RCx Process and Persistence of Savings





RCx process

-  Investigate and resolve operational deficiencies
-  Install and test Energy Efficiency Measures
-  Develop system-level benchmarks



Three-prong approach to sustain RCx savings

-  Facility monitoring
-  Utility bill analysis with whole building benchmarks
-  System-level benchmarks to detect deviations



Partnership Credits



Southern California Edison

■ Michael Lo, Program Manager



Southern California Gas Co.

■ Paulo Morais, Project Manager



County of Los Angeles – Internal Services Dept.

■ Howard Choy, Division Manager, ISD, Los Angeles County

■ Nora Hernandez, Section Manager, ISD, Los Angeles County



Cact Information

- N. "Amar" Amarnani,
 - County of Los Angeles – Internal Services Department
 - T: 323-267-2441, E: namarnani@isd.lacounty.gov

- Brian Roberts
 - County of Los Angeles – Internal Services Department
 - T: 323-267-3010, E: broberts@isd.lacounty.gov

- Michael Lo
 - Southern California Edison – Energy Efficiency Division
 - T: 626-633-3035, E: michael.lo@sce.com

- Paulo Morais
 - Southern California Gas Company
 - T: 213-244-3246, E: pmorais@semprautilities.com