

A large complex building retro-commissioning case study in Japan

Iwao Hasegawa and Kiyohiro Yamamoto

Building Performance Consulting, Inc.

Hideaki Nakajima and Masayuki Nakamura

Tokyo Gas Urban Development Co., Ltd.

Synopsis

The Shinjuku Park Tower building is a large building complex built in Tokyo in 1993 that includes office space, a shopping zone, and a hotel. It has 52 floors and a total building size of 2.84 million square feet. The owner of this building acquired ISO 14001 certification and needs to execute an energy conservation program.

Over the course of three years, the owner and the Commissioning Authority have conducted a retro-commissioning process that has resulted in greatly improved HVAC efficiency and operations.

This presentation will focus on a case study of the Shinjuku Park Tower building. This case study will review the retro-commissioning process of the HVAC system: the air handling units and control system. It will also detail how the owner and the Commissioning Authority worked together to coordinate the project.

About the Authors

Iwao Hasegawa is a chief consultant at Building Performance Consulting, Inc. He has worked as an engineer in building energy and environmental management for over 13 years.

Kiyohiro Yamamoto is a chief consultant at Building Performance Consulting, Inc. He has worked as an engineer in building energy and environmental management for over 15 years.

Hideaki Nakajima is a director at Tokyo Gas Urban Development Co., Ltd. Tokyo Gas Urban Development is the building owner of The Shinjuku Park Tower building.

Masayuki Nakamura is a manager of building management department at Tokyo Gas Urban Development Co., Ltd.

Introduction/Background

Building owners are concerned about how to optimize building performance during building operation. Occupants' requirements for building service and HVAC facility efficiency make energy saving one of the most important issues in building operations today. The percentage of energy consumption by HVAC in buildings is about 2:1 and occupies the biggest portion of the total energy consumption in commercial buildings in Japan. By applying logical conservation procedures and providing data-based evidence to existing buildings, commissioning implementation is expected to be an effective way to monitor the efficiency and operation & maintenance strategy of HVAC facilities.

The owner of Shinjuku Park Tower building received ISO14001 certification which scope doesn't include the hotel area in 2001 and implemented an environmental management system in order to reduce the environmental impact. Table 1 indicates the environmental charter and management target for this building in 2002. As shown in this table, the owner had tried to reduce energy consumption and waste by themselves for two years after receiving the certification. As for energy saving, the owner recognized that it was difficult to continue improving energy efficiency by themselves, and decided to cooperate with a commissioning agency and conduct retro-commissioning in this building.

| Policy | Objectives | Target | Method |
|--|-------------------------------------|--|---|
| 1 We will adhere to all domestic and international environmental regulations. | to conserve energy consumption | Electricity: 200,000kwh/y | 1. exchange fluorescent lamp(40W- 32W) |
| 2 We will save energy such as electricity, gas and chilled/ hot water from DHC. | | Cold water: 1,000GJ/ y | 1. adjust intake of outdoor air(3- 7F AHU) 2. change room temperature setting point |
| 3 We operate a co- generation system and water recycling system to reuse primary energy. | to save water usage | Cold water demand: 3.5GJ/ h | 1. adjust intake outdoor air(3- 7F AHU) 2. stop AHU at the peak hours 3. change supply water pressure setting point |
| 4 We promote recycling wastes with building occupants' cooperation. | | to promote recycling of waste | Recycling water: 4,000m ³ / y |
| 5 We reduce environmental impact in construction | to reduce the number of copy papers | 100%(recycling of garbage improve recycling rate of paper by 5%every year | |
| 6 We reduce the number of copy papers. | | 3%reduction of copy paper using recycled paper at building management office | |
| 7 We motivate employees to join environmental protection action. | to improve employees' motivation | educational seminar for environmental management | |
| 8 We review and improve our environmental management system by executives continuously. | | | |

Table 1 : Environmental policy, objectives and targets

Retro-commissioning Approach

Energy consumption analysis of the whole building

At first, we compared the building energy consumption with benchmark data in order to recognize the estimated reduction of energy consumption. **Figure A** shows the energy consumption data(MJ/sf²/year) for five years, and energy consumption has increased, as indicated in this figure. According to our estimate, the energy conservation rate would be 10-20%.

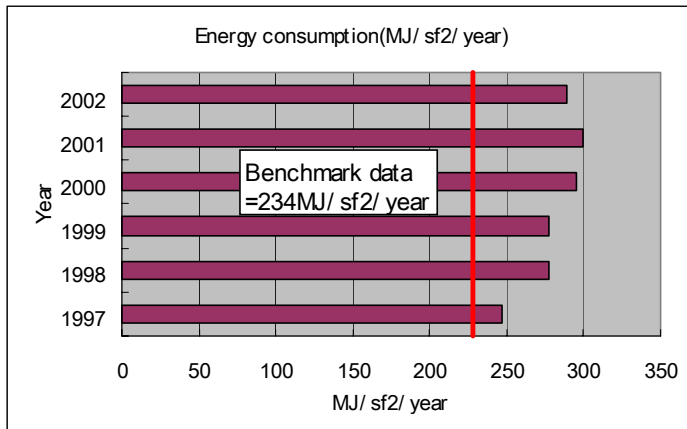

Figure A : Energy consumption for six years

Retro-commissioning target

The retro-commissioning project was targeted at operational improvements in the atrium and office lobbies. This was due to the owner's reluctance to risk making occupants uncomfortable by implementing energy conservation measures in occupied areas and also because the owner wanted to start with a small investment.

We classified the following three categories for the energy conservation measures in the atrium and lobby areas:

Operational improvement

There are several measures that have the advantage of needing a relatively small investment and being easy to implement; examples of these include: changing room temperature and setting points or adjusting control parameters in DDCs. On the downside, the energy savings that result will be commensurately the smallest of all the categories of improvement.

Adding energy saving equipment

Thousands of dollars are required to implement these measures, such as an inverter being added to an AHU or a chilled water pump being installed in order to change the control system from a constant air/water volume system to a variable air/water volume system. However, the building owner will get a greater return on their conservation investment than by simple implementation of operational improvement measures.

Renewal

These renewal measures, such as the renewal of a chiller from a low performing to a high performance model, require a large initial investment and are conducted every 15 years because of equipment deterioration.

Project Outline

Building description

The building is a 52-story, 2.84 million square feet high-rise building complex built in 1993. The building is of a modern steel concrete construction and consists of office space, hotel space, atrium space, and shopping space. An office area of 960,000 gross square feet is located on floors 9-37. The hotel(Park Hyatt Tokyo) is the main tenant on floors 39-52. A shopping center and restaurants are located on B1 floor and floors 3-8 and an atrium is on the 1st floor.

HVAC systems

A DHC (District Heating and Cooling system) provides chilled water (maximum:7000USRT) and steam (maximum:27,800kg/h). Chilled water is separated into two types. One is primary chilled water supplied from the DHC directly to the lower floors, and the other is secondary chilled water supplied through a heat exchanger. Air handling systems on the hotel floors consume this secondary chilled water through a heat exchanger system. There are two types of heating systems. One uses decompressed steam from the DHC directly and the other uses hot water through a steam/water exchanger.

The AHU(Air Handling Unit) system on the office floor is a 4-pipe system and connected VAV units. The atrium area AHU system is also a 4-pipe system. **Figure B** shows the process diagram of the heat source system and AHU system in the atrium. Room temperature/humidity are controlled by return air temperature/humidity.

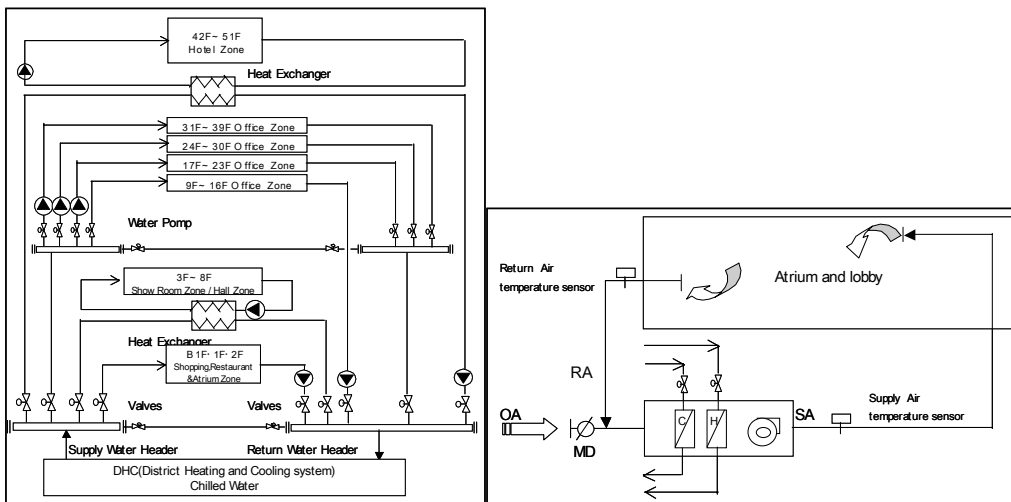

Figure B : HVAC system configurations

Retro-commissioning structure to promote energy conservation

In an effort to promote energy conservation, the building owner and building management firm held regular energy conservation meetings in which energy consumption data and the means of improving energy-efficient operations were reviewed. The retro-commissioning was conducted

under a contract between the building owner and the Commissioning Authority (CA), and included the preparation of plans for the measurement and verification of energy-saving benefits, actual measurement work, and performance verification based on the measured data. In addition, the CA participated in energy conservation meetings and presented specific work items involved in retro-commissioning so that they would not duplicate any of the energy-saving efforts that had already been undertaken by the building management firm. The management firm also assisted in the actual measurement work. The retro-commissioning structure is illustrated in **Figure C**.

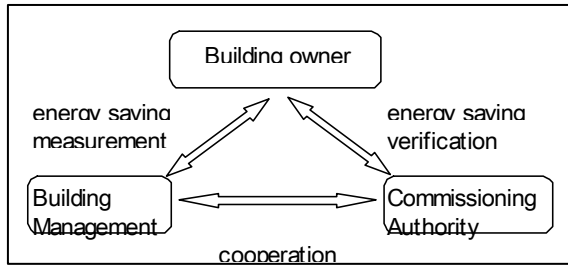

Figure C: The retro-commissioning structure

Verification procedures to save energy in the atrium and lobby

The atrium and lobby were chosen for retro-commissioning based on two reasons: the owner's requirement and the scale of the atrium's energy consumption. The energy consumed by air-conditioning the atrium and lobbies is estimated at approximately 5% of the total energy consumed by the complex. The measures focused on the following four items:

- Shut off the intake of outdoor air into the AHUs
- Change the temperature setting of the AHUs
- Stop the humidifying operation
- Prevent mixing losses in the 4-pipe AHU system

Figure D provides the process of verification covering the items tested, how they are tested, and how the effect is verified. Tests were conducted in each case of implementing and not implementing the respective test items. Test results were collected to compare the indoor environmental changes and the AHU operating conditions for verifying the effects on energy conservation.

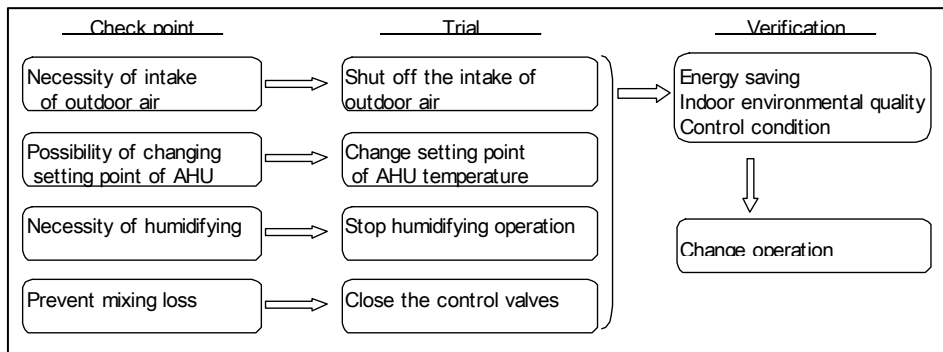

Figure D: Retro-commissioning flows in the atrium and lobby

Time and methodology of measurements

The energy-saving verification tests were conducted at three different times of the year—summer, fall and winter—with each test requiring about two weeks. **Table 2** shows what were tested and when. During each seasonal test, the changes in indoor environment were measured along with changes in the operating conditions of the AHUs connected to the atrium and lobby systems. **Table 3** shows the measuring instruments used and measurement details. The indoor environment was analyzed by measuring the temperature, humidity, and CO2 concentration while the AHU operating conditions, such as the supply air temperature, indoor room temperature, and degree at which valves were opened (chilled water, steam, and humidifying lines), were noted by recording data through a dedicated data gathering system. A schematic diagram of the atrium and lobby showing where the measurements were taken is illustrated in **Figure E**. Operating data was collected from two AHUs for the atrium system and seven AHUs for the lobby system.

Table 2: Measurement period and identification item

| Season | Measurement period | Identification |
|--------|-----------------------|--|
| Summer | 7/25/2003-8/7/2003 | Shut off the intake of outdoor air |
| Autumn | 10/16/2003-10/21/2003 | Normal operation |
| Winter | 1/29/2004-2/9/2004 | Shut off intake of outdoor air/ change setting point Stop the humidifying operation |

Table 3: Measurement equipment and points

| Equipment | points | Interval |
|-----------------------|--|------------|
| Thermal sensor | Temperature :10 points in the atrium/ lobby and 2 points of outdoor air | 10 minutes |
| | Humidity :10 points in the atrium/ lobby and 2 points of outdoor air | 10 minutes |
| CO2 sensor | CO2 density :6 points in the atrium/ lobby and 2 points of outdoor air | 1 hour |
| Data gathering system | Control condition of Air Handling units (Control valve position, supply air temperature, return air temperature, etc) | 10 minutes |

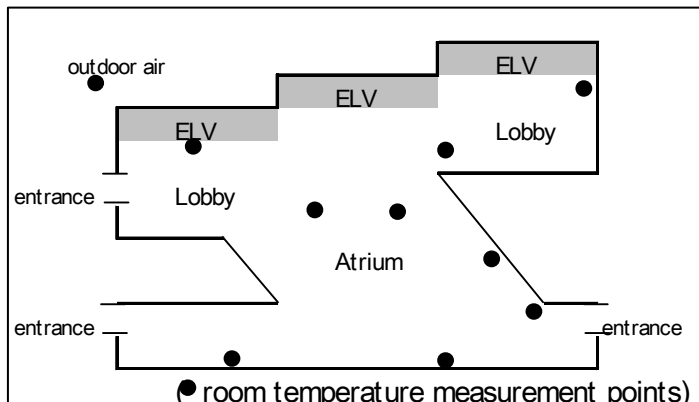

Figure E: A schematic diagram of the atrium and lobby

Analysis of measured data and verification of energy conservation

Effect of shutting off the intake of outdoor air

The AHUs for the atrium and lobby systems recirculate the air by mixing returned air with outdoor air and then through a cooling or heating process if appropriate.

The intake of fresh outdoor air into the AHUs is presumably intended to provide positive air pressure inside the atrium and lobby, thereby preventing condensation and/or outside air from flowing in. The atrium and lobbies are constantly subjected to the inflow of outside air due to the traffic of people entering and exiting through the entrances. This fact prompted us to consider shutting off the intake of outdoor air into the AHUs to reduce any outdoor air-related load and conserve energy. To verify the effect of operations without the intake of outdoor air, it is necessary to make an accurate comparison of energy consumption by operating the systems with and without the intake of outdoor air based on sufficiently similar outside air conditions. By choosing days of extremely similar outdoor air temperatures, we measured the degree at which the valve in the chilled water line to the AHU was opened for the respective operating cases and estimated the amount of reduction of the chilled water supply. Shutting off the intake of outdoor air would increase CO₂ concentrations within the indoor environment. Therefore, CO₂ concentrations were measured to determine how the indoor environment could be affected by shutting off the intake of outdoor air.

CO₂ concentrations were measured during one day of operation, each with and without the intake of outdoor air. **Figure F** shows the indoor and outdoor CO₂ concentrations measured on July 28 and August 4. Except for the two hours from 8:00 to 10:00 on August 4, the graphs show a fairly constant indoor CO₂ concentration level of about 500 ppm, which indicates that indoor CO₂ concentrations are not affected by the number of people indoors or by the intake of outdoor air. The graphs also indicate that indoor CO₂ concentrations were apparently largely dependent on outside CO₂ concentrations. Based on these findings, we concluded that shutting off the intake of outdoor air into the AHUs should not affect the indoor environment.

Presented in **Figure G** is a comparison of the degrees at which the control valves were opened and the measurements that were taken with and without the intake of outdoor air. Although it varied to some extent depending on the time of day, the degree at which the control valve for chilled water was opened was 10% to 20% greater in both the atrium and lobby systems when outdoor air was allowed into the system. The tests for the two cases were conducted on days with similar outdoor air temperatures during the overall test period: the mean outdoor air temperature during operations (from 7:00 to 21:00) was 27.6°C when the intake of outdoor air was shut off (July 31) and 28.6°C when the intake of outdoor air was allowed (August 6).

According to the measured data, we estimated how much the cooling energy could be lowered by shutting off the intake of outdoor air into the nine AHU systems responsible for the atrium and lobbies. The calculation was based on the relative comparison of flow volumes estimated from the total opening of the chilled water valves in each case of operation, with or without the intake of outdoor air, against the design flow capacity when the valve is completely opened. A comparison of the data obtained on July 28 and August 6 indicates an estimated reduction of 232 m³/day (approximately 27%). Energy-saving measures of this type are considered effective when the outdoor air enthalpy is higher than that of indoor air. In Japan, the months from July through September usually meet this condition. We therefore estimated the amount of energy savings applicable to July through September based on the acquired data, assuming that the air

conditioning is in operation 14 hours a day and that there is a supply and return temperature difference of 9°C. The estimate indicates that approximately 350 GJ of energy can be saved per year.

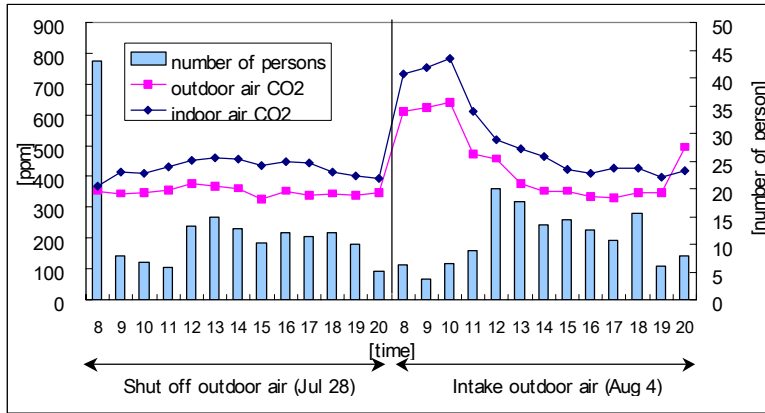

Figure F : Indoor and outdoor CO2 concentrations

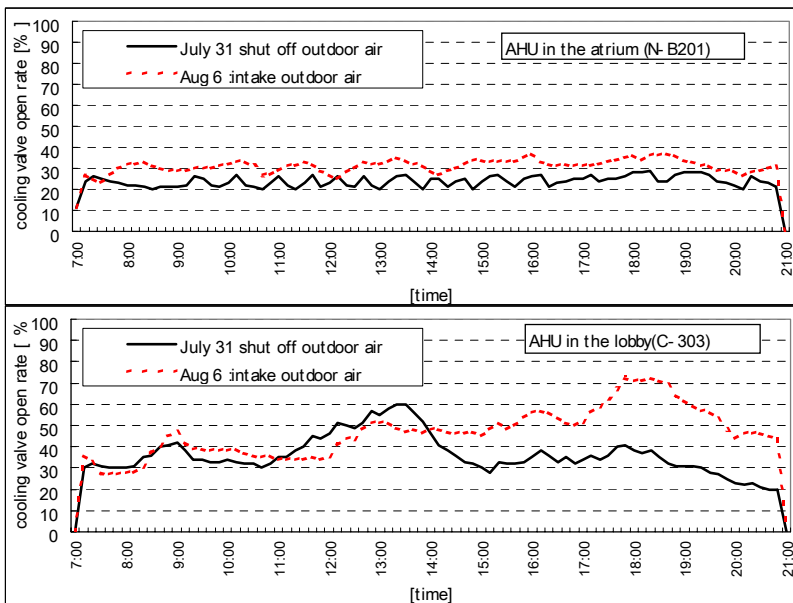

Figure G : Cooling control valves open rate

Conserving energy by changing the temperature setting

Verification tests were conducted in winter to determine what effect on energy conservation could be expected from changing the air-conditioning temperature setting. In this particular building, the atrium and lobby temperature is usually set at 22°C during winter. In the tests that were conducted, the setting was lowered to 20°C, and the degree at which the steam valves were opened was recorded in order to estimate the reduction in heating energy (steam).

Figure H compares the degrees at which the control steam valve was opened and the measurements that were taken as the temperature setting was changed. The data indicates the degree at which the steam control valve was opened was approximately 20% smaller when the temperature setting was lowered to 20°C. The tests were carried out on two different days with similar outdoor air temperatures during the overall test period. On the two days (January 31 and February 9), the mean outdoor air temperature was 8.2°C during the operation of the air-conditioning systems (from 7:00 to 21:00).

Figure I compares mean atrium temperatures and return air temperatures at the AHUs taken on the two days. The AHU operation is controlled according to the return air temperature. The return air temperature was approximately 21°C, based on the 22°C temperature setting on January 31, while the same was approximately 20°C, based on the 20°C setting on February 9. In each case, it took hours in the morning for the temperature to stabilize.

Based on the test results, we estimated the amount of steam that could be reduced from changing the temperature setting. Calculations based on the measured degree at which the steam valve was opened indicate that approximately 0.6 tons/day, or approximately 50 tons/year based on 90 days of heating operations, can be conserved if the temperature setting is lowered from 22°C to 20°C.

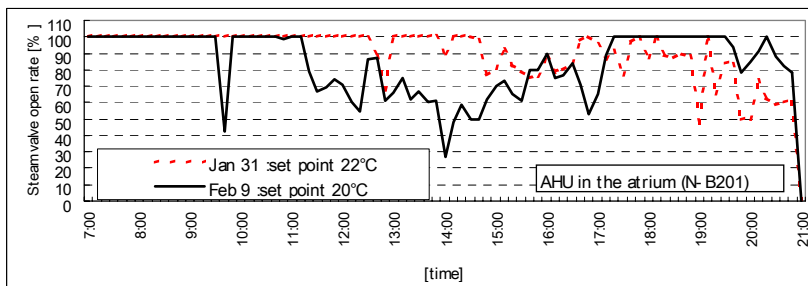

Figure H : Steam control valves open rate

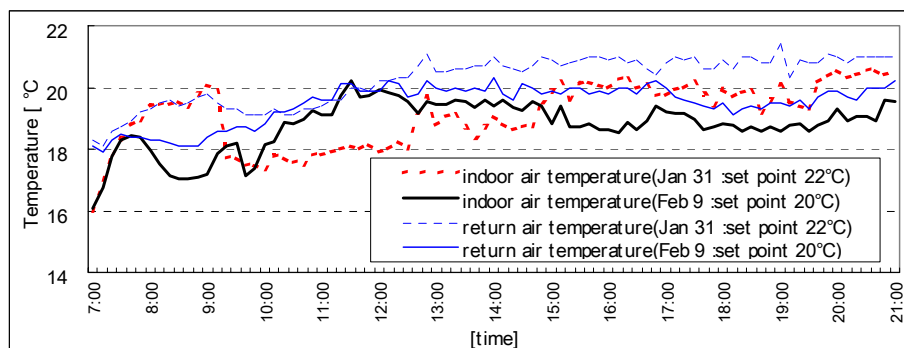

Figure I : Mean atrium temperatures and return air temperatures

Effect of stopping the humidifying operation

The primary purpose of humidifying a room in winter in Japan is to reduce static electricity. If the humidifying operation can be shut down without causing an electrostatic problem in the atrium or lobby, energy can be conserved. During winter, the AHUs for the atrium and lobby systems are set to operate at 40% humidity by controlling a supply of steam. Based on measured changes in the degree at which the humidifying valve is opened, we estimated the heat load (steam) that could be reduced when the humidification systems are shut down.

Figure J shows indoor relative humidity measured with and without humidification. The indoor relative humidity stayed within the 25–35% range in both cases, indicating no appreciable drop in relative humidity when the humidification system is shut down. As in the case of the CO₂ concentrations noted in the section of shutting off the intake of outdoor air, we understand that the above had much to do with the fact that outside air was being introduced into the atrium and lobbies due to the traffic of people going through the entrance doors.

Based on the test results, we estimated the amount of steam that can be reduced by shutting down the atrium and lobby humidifying systems. Calculations based on the measured degree at which the steam valve was opened indicate that approximately 1.4 tons/day, or approximately 126 tons/year based on 90 days of humidifying operations, can be conserved.

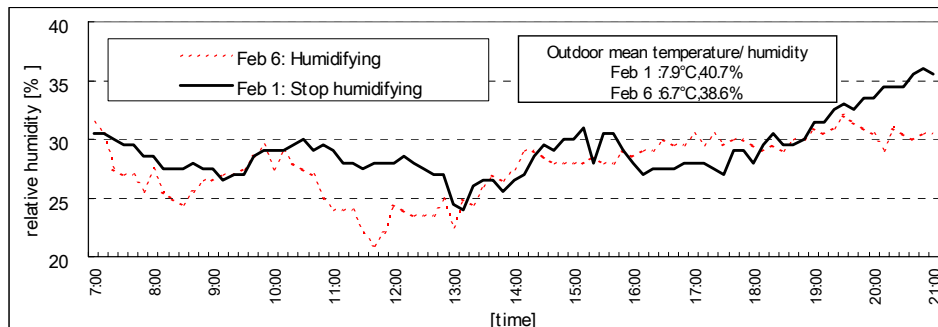

Figure J : Indoor relative humidity measured with and without humidification

Close the control valves for preventing mixing loss

The AHUs for the atrium and lobby employ 4-pipe systems for the following two major reasons: 1) tenants want heating and cooling available year-round and 2) district heating and cooling (DHC) systems are used and provide steam as a direct source of heating. In large spaces, like the atrium and lobbies where precise air-conditioning control may not be critical, valves in either the chilled water or heating water lines may be closed to minimize any mixing losses, thereby conserving energy.

In this building, prior to our tests, measures to conserve energy by manually controlling valves in non-critical control sections had already been implemented, saving some energy in limited sections. We actually measured and verified the opening and controlling of those valves. **Figure K** presents the measured values of opening the chilled-water and steam valves in the AHUs for the atrium on October 19. It shows that the steam valves were fully opened in the morning until the temperature reached the set point of 22°C and that, immediately after the temperature stabilized, the chilled water valves were opened to keep the temperature at the set level.

From the above, we estimate that chilled water can be conserved to some extent by shutting off relevant valves, depending on the outdoor air temperature, and/or by readjusting the temperature control settings.

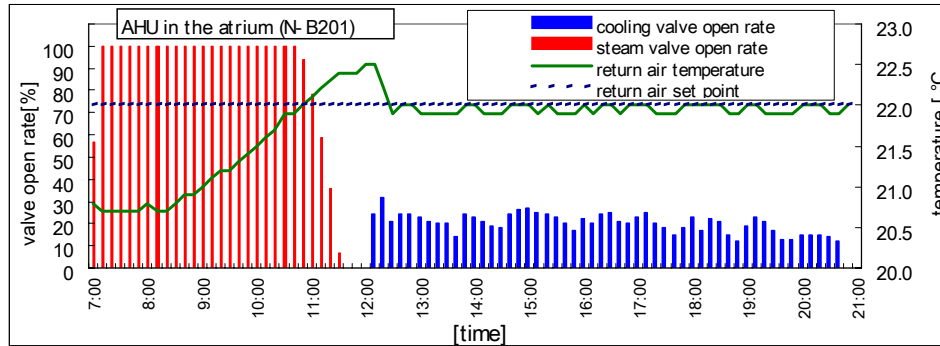

Figure K : Cooling and steam control valve open rate

Retro-commissioning results

Table 4 shows the retro-commissioning results for three years. We presented the results for the atrium and lobby. The building owner conducted these measures according to our recommendations and successfully reduced energy costs.

Table 4 : Summary of retro-commissioning results

| | № | Place | measurements | Energy saving | | Verification |
|----------------------|---|----------------------|--|---------------------------------------|-------------|-----------------------|
| | | | | (\$ / year) | (GJ/year) | |
| Atrium /Lobby | 1 | Atrium/Lobby | Shut off intake of outdoor air in summer | 9,300 (chilled water) | 389 | Measurement in summer |
| | 2 | Atrium/Lobby | Cotrol No. of AHUs in summer | 2,900 (Electricity) | 246 | Measurement in summer |
| | 3 | Atrium/Lobby | Natural ventilation in summer | 46,400 (chilled water+Electricity) | 2,776 | Calculation |
| | 4 | Atrium/Lobby | Stop AHU in autumn | 2,900 (Steam) | 270 | Measurement in autumn |
| | 5 | Atrium/Lobby | Shut off intake of outdoor air in winter | 5,000 (Steam) | 597 | Measurement in winter |
| | 6 | Atrium/Lobby | Change setting point 22.→ 20°C(winter) | 1,840 (Steam) | 171 | Measurement in winter |
| | 7 | Atrium/Lobby | Stop the humidifying operation | 4,670 (Steam) | 435 | Measurement in winter |
| Office floor passage | 1 | Office floor passage | Shut off intake of outdoor air in summer | 20,350 (chilled water) | 850 | Measurement in summer |
| | 2 | Office floor passage | Change setting point 26.→ 28°C(summer) | 42,070 (chilled water) | 1,758 | Measurement in summer |
| | 3 | Office floor passage | Stop AHU(1 hour in summer) | 4,010 (chilled water) | 167 | Measurement in summer |
| | 4 | Office floor passage | Demand management in summer | 173,380 (chilled water) | - | Measurement in summer |
| | 5 | Office floor passage | Outdoor air cooling in autumn | 29,500 (chilled water) | 1,229 | Measurement in autumn |
| | 6 | Office floor passage | Stop the humidifying operation | 11,200 (Steam) | 1,043 | Measurement in winter |
| | 7 | Office floor passage | Change setting point 23°C→ 20°C(winter) | 7,340 (Steam) | 684 | Measurement in winter |
| total | | | | 360,860 | 10,615 | |

Conclusion

This report covered findings from the retro-commissioning process that was conducted to explore means of energy savings in building operations.

Our measurements provided a clear picture of the indoor environment and air-conditioning controls before implementing changes and allowed us to verify that energy savings could be expected by changing operational protocol. This proved to be an effective means of achieving energy conservation in the building operation stage. We intend to further extend the scope of retro-commissioning for energy conservation measures in the future.